

Transforming Electricity Governance in India

Has India's Power Sector Regulation Enabled Consumers' Power?

Ashish Khanna

Daljit Singh

Ashwini K Swain

Mudit Narain



WORLD BANK GROUP

Energy and Extractives Global Practice Group

May 2015

Abstract

Consumers' participation in regulatory decision-making in infrastructure sectors can be critical to ensure effective regulatory governance. Providing avenues for enabling consumers' voice in the regulatory process expands the information base available to regulators in their decision-making, and is critical for ensuring sustainability of policy and regulatory decisions. However, in the reform process of many developing countries' power sectors, the primary focus has been on the sector's technical aspects, with inadequate effort to improve the experience of consumers, whether through better quality of service or by ensuring their participation in the regulatory process. This shortfall has often undermined the public's understanding of and demand for reforms, often reflected in political reversal of key policy decisions. This paper examines the level and

quality of consumer participation and protection in five states in India through a review of documents, surveys of consumers, and detailed interviews with key stakeholders. As mandated by law, all states have established standards of performance regulations and set up grievance redressal mechanisms; however, these bodies have not reached the desired level of effectiveness. Similarly, although provisions for consumer participation in regulatory proceedings exist, their adoption is often symbolic and without substantive and deliberative participation. Drawing on analysis of the Indian experience and international best practices, the paper recommends a paradigm shift in pursuing enhanced consumer satisfaction and voice in regulatory decision-making as a central objective of power reforms.

This paper is a product of the Energy and Extractives Global Practice Group. It is part of a larger effort by the World Bank to provide open access to its research and make a contribution to development policy discussions around the world. Policy Research Working Papers are also posted on the Web at <http://econ.worldbank.org>. The authors may be contacted at akhanna2@worldbank.org.

The Policy Research Working Paper Series disseminates the findings of work in progress to encourage the exchange of ideas about development issues. An objective of the series is to get the findings out quickly, even if the presentations are less than fully polished. The papers carry the names of the authors and should be cited accordingly. The findings, interpretations, and conclusions expressed in this paper are entirely those of the authors. They do not necessarily represent the views of the International Bank for Reconstruction and Development/World Bank and its affiliated organizations, or those of the Executive Directors of the World Bank or the governments they represent.

Transforming Electricity Governance in India

Has India's Power Sector Regulation Enabled
Consumers' Power ?

Ashish Khanna^{*}
Daljit Singh[†]
Ashwini K Swain[‡]
Mudit Narain[§]

^{*} Ashish Khanna is Lead Energy Specialist, World Bank. Email: akhanna2@worldbank.org

[†] Daljit Singh works as a consultant on energy policy in New Delhi. Email: daljitss@gmail.com

[‡] Ashwini K Swain is Director, CUTS Institute for Regulation & Competition, New Delhi. Email: ashwini@ashwiniswain.net

[§] Mudit Narain is at the Centre for Innovation Incubation and Entrepreneurship (CIIE), Indian Institute of Management, Ahmedabad's business incubator. He was with the World Bank's Energy Practice when this study was initiated. Email: Narain.mudit@gmail.com

Acknowledgements

The paper is based on a study conducted by the authors under the Service Delivery Cluster Analytical Work for Government of India, with financial support from The World Bank and Department for International Development (UK). The team benefited from valued guidance provided by Vikram Chand, Lead Public Sector Specialist of the World Bank, Sanjeev Ahluwalia, Advisor, Observer Research Foundation and Udai Singh Mehta, Director, CUTS International. Research assistance was provided by Molshree Bhatnagar and Sarada Prasanna Das of CUTS Institute for Regulation & Competition, and Gaurav Shukla of CUTS International.

LIST OF ABBREVIATIONS

AER	Australian Energy Regulator
ANEEL	<i>Agencia Nacional de Energia Elctrica</i> (Brazilian Electricity Regulatory Agency)
ATE	Appellate Tribunal for Electricity
CAD	Consumer Affairs Division
CCP	Consumer Challenge Panel
CCP	Consumer Challenge Panels
CGRF	Consumer Grievance Redressal Forum
CGRM	Consumer Grievance Redressal Mechanism
COAG	Council of Australian Government
CP&P	Consumer Protection And Participation
CR	Consumer Representative
CSO	Civil Society Organization
DERC	Delhi Electricity Regulatory Commission
E Act 2003	The Electricity Act, 2003
ECA	Energy Consumer Australia Ltd
FoR	Forum of Regulators
GERC	Gujarat Electricity Regulatory Commission
GRA	Grass-Roots Advocate
HERC	Haryana Electricity Regulatory Commission
ICT	Information and Communication Technology
KERC	Karnataka Electricity Regulatory Commission
MERC	Maharashtra Electricity Regulatory Commission
MSEDCL	Maharashtra State Electricity Distribution Company Limited
NEM	The National Electricity Market
OCA	Office of Consumer Advocacy
OECD	Organization for Economic Cooperation and Development
Offer	Office of Electricity Regulation
Ofgem	Office of Gas and Electricity Markets
PSR	Priority Services Registrar
PUC	Public Utility Commission
RERC	Rajasthan Electricity Regulatory Commission
RoE	Return on Equity
RWA	Resident Welfare Association
SAC	State Advisory Committee
SCA	State Consumer Advocate
SCER	Standing Council on Energy and Resources
SERC	State Electricity Regulatory Commission
SoP	Standards of Performance
TVS	Technical Validation Session

1. Introduction

*Too often, services fail poor people- in access, in quantity, in quality. But the fact that there are strong examples where services do work means governments and citizens can do better. How? By putting poor people at the center of service provision: by enabling them to monitor and discipline service providers, by **amplifying their voice in policymaking**, and by strengthening the incentives for providers to serve the poor.*

-World Development Report 2004: Making Services Work for Poor People

In the past two decades, consensus has emerged in academic and policy arenas about the importance and desirability of public participation in resource management and service delivery. With the objective to amplify the voice of all consumers in decision-making, direct participation has been advocated for all levels of policymaking, ranging from micro decisions at the local level to technical matters like regulatory policies at the macro level.

In the electricity sector, most developing countries have unbundled, or are in the process of unbundling, their utilities, followed by the establishment of an independent regulator. However, it has been observed that most of these reforms have focused on the sector's technical aspects, with far less attention to quality of service and consumer participation in decision-making and regulation. Furthermore, there has been very little research undertaken on the impact of the recently introduced regulatory process on improving consumer service, either through improved grievance redressal mechanisms or through an enhanced consumer voice in regulatory decision making. This paper explores the experience, through a qualitative and quantitative assessment, of five Indian states along these two dimensions after more than a decade of establishment of a regulatory system. The paper also seeks to contribute to the development of international best practices for more effective consumer service that could be adopted by developing countries as they reform their electricity sector, to ensure better grievance redressal and more effective consumer participation in the regulatory process.

1.1 Benefits of Consumer Participation

Mitcham (1997) suggests several reasons for direct participation of consumers in regulation, as compared with primarily relying on experts to represent public interests. First, no expert decision is free from values and influences. Experts are in the milieu of the public discourse in the media and thus are subject to ongoing value discussions. Second, participation is necessary to ensure social acceptance of technical decisions, in order to address the *Not In My Backyard* phenomenon. Policies and regulations become more sustainable if the public is aware of the consequences and ready to deal with them. Third, experts might have vested interests or inherent mind-sets inconsistent with the public interest. Thus, consumer participation is necessary to ensure representation of the public interest and to ensure social acceptance of regulatory decisions.

Advocates of public participation fall into two groups: one views participation as a means to achieve institutional efficiency, and the other sees participation as furthering the goals of empowerment, equity and democratic governance (Puri, 2004). The first focuses on consumer participation as a way to improve service quality, and the second focuses on development of social cohesion. Both these views are valid, even though they emphasize different aspects of participation as a way to rebuild trust in the system on the part of consumers.

1.2 Levels of Participation

Participation is not something that any system either has in the regulatory framework or does not. There are varying levels of participation, and there is a spectrum of the level and quality of consumer participation. Analyzing citizen participation, Arnstein (1969) presented a ladder of participation with eight rungs/levels, which can be put into three broad categories: Non-participation, tokenism,

and citizen power. While 'citizen power' is the most desirable in the ideal world, it may not be feasible to achieve in the real world, especially in the case of technical decision making. The desired goals of transparency and accountability in technical decision-making at the macro level may be better achieved through informing, consultation and placation, without much transaction cost.

Building on Arnstein's ladder of participation, consumer participation in the regulatory framework can be thought of occurring at the following five incremental levels (adapted from Muzzin 2005). While the highest level of participation (i.e. empowerment) has often been desired, it is far from practicable in regulation of electric grid systems. However, an effective regulatory system must strive to achieve the middle level of 'influence', with information and consultation as prerequisites.

- a) *Information*: At this level, the focus is on one-way flow of information from regulators to consumers.
- b) *Consultation*: Consultation is one step ahead where the regulators seek inputs (in form of non-binding advices) from the consumers, other interest groups, and/or their representatives to inform the regulatory process.
- c) *Influence*: At this level, there is some mechanism to ensure that consumers' inputs are taken into account in the decision-making process.
- d) *Partnership*: This level involves some degree of 'redistribution' of decision-making power as consumers are granted the right to negotiate with the regulators and other stakeholders.
- e) *Empowerment*: This level implies self-regulation, where the consumers are empowered to manage their own infrastructure. However, such a level of participation is more suitable for small infrastructure networks (like micro-grids or community water supply systems) with a much more homogeneous consumer base and is likely to be infeasible for large networks like the Indian grid-based electricity systems with a large and fissiparous consumer base.

In an ideal (yet practicable) case, Muzzini (2005) identifies three core functions to be performed by the regulators to ensure consumer participation in regulatory process. These are: (a) informing consumers; (b) resolving consumer complaints (grievances); and (c) soliciting consumer inputs.

1.3 The Indian Context

Box 1 provides background information on the recent history of the electricity sector in India. In spite of tremendous gains since independence in the electricity generation capacity in the country, and structural change in the sector, the Indian power sector remains mired in problems. About 300 million people still do not have access to electricity (Pargal and Bannerjee, 2014), and even those who have access to electricity do not get reliable supply, particularly in rural areas. The financial health of many distribution companies continues to be fragile. Introduction of regulatory commissions has brought about some transparency, but has not been able to effectively address these problems. Much has been written about reforming the sector, and the steps needed to remedy the current situation. One aspect of reforms that has not been analyzed and investigated sufficiently is consumers' experience with their electricity service and measures to protect consumers' interests in the sector; neither has much been said about incorporating consumers' voice in decision-making.

By themselves, consumer protection and participation (CP&P) will not solve the problems in the sector, but they are likely to lead to improvements in the decision-making environment and thus catalyze other improvements. It is not that the consumer has been completely absent from the minds of the people drafting laws dealing with the power sector. Successive legislations dealing with the sector have paid increasingly greater attention to consumer interests. However, even in the most recent legislation, the Electricity Act of 2003 (E Act 2003), the considerations leave room for considerable improvement (see Box 2).

1.4 Approach Used for the Study

With the objective to evaluate the current state of consumer participation and protection in electricity regulation, the study looked into practices and experience in five states: Delhi, Haryana, Karnataka, Maharashtra and Rajasthan. The selected states were chosen because they provide a diverse mix in terms of political economy, size, electricity consumer base, and varying level of reforms implemented in the sector.

Consumer protection and participation were assessed along two dimensions: (1) grievance redressal; and (2) consumer participation in regulatory proceedings. In order to assess the level of consumer protection and participation, a three level analysis was performed using multiple data sources as given in Table 1. A review of the structure and processes was undertaken to understand the statutory and regulatory requirements for consumer protection and participation; a study of the observed outcomes gave an assessment of the level of grievances and the level of consumer participation taking place in the five states. Through surveys and interviews, consumers' perception of the level of consumer protection and participation in the five states were checked to see if they were consistent with the observed outcomes. Together, the three types of assessments gave an indication of the effectiveness of consumer involvement in the regulatory process. For more detail on the study and the results, please see the complete project report (CUTS, 2015).

1.5 Layout of the Paper

Before delving into the experience in the five states, the next section (Section 2) discusses briefly the experience with CP&P in four countries: USA; UK; Australia, and Brazil, to see what lessons that experience may have for India. Section 3 describes the state of grievance redressal and consumer protection in the five states based on this study. Section 4 follows with an assessment of the level of consumer participation in the states based on this work. The final section (Section 5) pulls together the findings of this study and provides recommendations for improving consumer protection and participation. It is hoped that these recommendations will be useful not only for Indian states but also for other countries around the globe as they reform their respective electricity sectors.

Table 1: Study Approach to Assess Consumer Engagement in Regulatory Processes

Focus of Assessment	Grievance Related	Inputs for Regulatory Issues
Structure and Processes	Review of documents; Semi-structured interviews	Review of documents; Semi-structured interviews
Observed Outcomes	Analysis of CGRF and Ombudsman data	Review of proceedings and orders
Consumers' Perception	Surveys; Semi-structured interviews	Semi-structured interviews

BOX 1: Electricity Act 2003 and Recent History of the Indian Power Sector

In response to the halting reforms at the state level, the central government in early 2000s stepped in to replace the legal framework for electricity governance that had been in place for more than five decades. The Electricity Act 2003 was enacted in May 2003. This Act was introduced as a harmonizing self-contained legislation, focused on encouraging private sector participation in all three segments of electricity system and distancing the regulatory responsibilities from the governments. The Act repealed and replaced all the existing electricity laws in the country. The thrust of the Act was to lead the sector towards a market dominated by private players. The policy makers expected that private sector participation, with competitive profit motives, would unwind the system of perverse incentives in the sector. However, the Act has had limited success in

addressing the poor infrastructure, lack of transparency and the political-economy problems in the sector that were responsible for the prevailing crisis. While the states have largely segregated the different segments of electricity system, corporatized them and established independent regulators, the results of the reforms have fallen short of the expectations of the government. In the absence of much needed political reforms in the sector, these measures have failed to transform the sector and achieve the reform objectives.

BOX 2: Evolution of Consumer Protection and Participation in the Indian Electricity Sector

While there has been some consideration of consumer safety and consumer interests, the various legislations for electricity regulation have not emphasized 'consumer satisfaction and participation'. The Indian Electricity Act 1910 was the first major milestone in Indian electricity policy that governed the private-sector dominated sector for about four decades, till independence. The Act, for the first time, emphasized 'consumer safety' in electricity system and also identified the obligations of service providers to their consumers.

Immediately after independence, seeking to overhaul the sector, India introduced the Electricity (Supply) Act 1948, which put a deeper thrust on consumers' interests. The Act stressed access to minimum quality and quantity of supply to every citizen, at an affordable price. While once again there was no mention about consumer participation or consumer grievances, the Electricity (Supply) Act made provisions for advisory committees at the State and the local level.

The Electricity Regulatory Commissions Act 1998 made clear provisions for representation before the regulatory commissions in all their proceedings, which has been retained in the succeeding legislation. However, throughout the 1990s and early 2000s, it appears the governments were much more focused on technical improvements, loss reduction, commercial viability and overall efficiency, which were expected to be achieved through private participation, commercialization and tariff rationalization. Unlike the global discourse, there was less consideration of fostering consumer participation as a strategy to ensure social acceptance and legitimacy of the reform initiatives.

The 2003 Act made three relevant provisions for representation of consumer interests and promotion of consumer participation. First, retaining the provision for State Advisory Committees at the SERC level (as in 1998 Act), the Act allowed representation of various consumer interests in the regulatory process. Second, it required the regulatory commissions to hold regular public consultations and hearings on important matters to seek their inputs. Third, the act made provisions for Consumer Grievance Redressal Forums (CGRFs) at the discom level and one or more Ombudsman at the state level, to ensure accountability of service providers to consumers, and build consumers' trust in the system. The 2003 Act is the first in the series of regulations to give significant thought to consumers' requirements, by mentioning 'protecting interests of consumers' as one of the objectives in the preamble.

From this brief history, it can be seen that keeping with the changing political economy and governance structures, succeeding legislations have widened the considerations for consumer interests. However, even in the most recent legislation, the considerations remain far from the desired level and global best practices.

2. International Experience in Consumer Protection and Participation

The last section provided the theory and rationale for consumer participation in regulatory decision-making. It was felt that, before examining the experience in India, it would also be very useful to see how consumer participation and protection has been applied practically in countries with more evolved regulatory regimes. Ideas from international experience could then be evaluated for applicability during the review of the experience in the five Indian states. In that context, the study included a review of the experience of four other countries in consumer protection and participation: (1) USA; (2) UK; (3) Australia; and (4) Brazil. USA has a long history of regulation and consumer advocacy in the electricity sector. Moreover, regulation of electric utilities in India is closely modeled along the US system, and therefore it was expected that the experience in the US would be very important for improving CP&P in India. UK and Australia both rely on markets for setting energy prices, and given that India is considering greater introduction of markets and the separation of carriage and content in the electricity sector, it would be useful to understand how

these two countries have fared in their respective approaches. Perhaps no country has embraced public participation in policy-making in the way Brazil has done, and therefore, it too was included.

2.1 United States of America (USA)

Currently, consumers' interests are protected through a two-tier system. In the first tier, consumer affairs divisions (CADs), which are present in most public utility commissions (PUCs), handle complaints, help individual consumers with understanding their bills and in resolving disputes with utility companies. CADs also help with consumer education and consumer research (Sevel, 2001). In the second tier, consumers' collective interests are advanced through representation in regulatory proceedings before the PUCs. Two types of advocates represent consumers' interests. One is a state consumer advocate (SCA) who is appointed, in most cases, by the government to act on behalf of consumers. The other type of advocate is a grass-roots advocate (GRA), generally a private organization that promotes the interests of its members or of specific groups of consumers. Some examples are environmental groups or groups focused on low-income consumers.

Even though there is no any deliberate or explicit agreement between them, SCAs and GRAs perform complimentary roles in representing the interests of small consumers. SCAs with ample resources but constrained by statutes to represent all consumers or the public as a whole, generally focus on the overall rate level (revenue requirements) issues which do not "pit one segment of consumers against another" (Gormley, 1983). The expertise required to examine revenue requirements issues is not a major obstacle for state consumer advocates. In contrast, GRAs with fewer resources, lower level of expertise but more flexibility, focus on issues such as rate design, differences in quality of service between segments of consumers, and other such less complex issues. These issues often pit one group of consumers versus another, but "...that conflict is not a legal or political hurdle for grass-roots advocates" (Gormley, 1983).

SCAs have been created to help consumers who are often underrepresented in PUC proceedings (Stein, 2012). These are mostly small consumers who, when compared with the utilities and other organized interests, are unable to represent themselves for three reasons: (1) because they are dispersed, and hence less able to organize; (2) because of lack of the expertise and resources required to participate in technical proceedings; and (3) they are less likely to be heard by the PUC. SCAs help overcome these barriers to participation. Earlier, a Commission that had been making decisions with almost no inputs from consumers, "... is now presented with a consistently present and technically capable voice speaking for consumers (Stein, 2012)." Thus, in addition to helping the voice of small consumers to be heard by the PUC, the SCA adds to the information base that the PUC uses to set agendas, develop alternatives and make final policy choices (Rossi, 1997).

SCAs have full rights for intervention in proceedings including access to all information filed in cases in which it intervenes, and the right to appeal PUC decisions (RAP, 2014). Over the years, SCAs have saved consumers considerable sums of money through their intervention in a variety of cases such as: petitions to increase tariffs; mergers and acquisitions by utilities; and in cases of wholesale market and transmission issues through representation in regional coalitions (CT-OCC, 2011, 2012a and 2012b; CA-ORA, 2014; IL-CUB, 2012; NH-OCA, 2012) . A recent study (Fremeth et. al., 2013) found that states with SCAs had fewer rate reviews with utilities postponing requests for rate review, and the allowed return on equity (RoE) was 0.45 percentage points lower than in states without SCAs.

In summary, the US seems to have done reasonably well compared with other countries in protecting consumers and providing avenues for representation of consumers' interests. There are two main reasons for this success: (1) openness to participation and transparency and the resulting availability of information; and (2) presence of a strong advocate for small consumers in the form of the SCA.

2.2 United Kingdom (UK)

Since the privatization of the electricity sector in UK in the early 1980s, there have been many changes in the institutional structure and processes for ensuring consumer protection and representation. At the time of the privatization of the electricity sector, regional consumer committees were set up as part of the Office of Electricity Regulation (Offer), later known as the Office of Gas and Electricity Markets (Ofgem). However, criticism that they were ineffective and not independent led to proposals for establishment of consumer councils that were independent of the regulator, and that would represent consumers regionally and nationally. This led to the Utilities Act in 2000 which established Energywatch (Graham, 2014).

Energywatch was an independent body whose members were appointed by the Secretary of State (Crew and Parker, 2006). It was intended to be an advocate for the interests of all consumers, particularly the vulnerable and disadvantaged. In that role, it was also to provide advice on consumer matters to public authorities and licensees. One of its functions was to investigate complaints. If it could not reach a settlement, the matter was referred to Ofgem. In addition, it was required to publish information on the performance of licenses against any service. While there was some improvement with Energywatch, there were concerns that the level of expenditure was very high compared to the achievements, and that there was not sufficient focus on reducing the number of complaints. Consequently, in 2007, a new body called Consumer Focus was created to replace Energywatch. It had an Extra Help Unit for vulnerable consumers such as the elderly.

The coalition government that came into power in 2010 was committed to reduce the number of public bodies, and rationalize how consumer protection was delivered. Consequently, it abolished Consumer Focus (which had been renamed Consumer Futures for a short period), and its functions were transferred to Citizens Advice – a generalist charity agency that gives consumers advice and researches and advocates for consumers. Complaints continue to be handled by the Ombudsman (Graham, 2014).

Consumers are not satisfied with their electricity service (Graham, 2014; Thomas, 2014). One of the main reasons is the rise in energy prices and the perception that prices only go up. A survey commissioned by Consumer Futures in November 2013 of the experiences and priorities for small businesses regarding regulated markets found that the topmost concern was the cost of electricity (Citizens Advice, 2014). Another reason for the dissatisfaction with electricity service is the confusing number and presentation of tariffs by suppliers. The recently passed Energy Act (2013) addresses some of these issues regarding tariffs.

2.2.1 Overview of Consumer Protection in Current Regulatory Framework

Retail energy prices are not regulated by Ofgem but charges for the network are regulated. For energy prices, Ofgem's philosophy is to promote competition, which it believes will drive down prices and lead to better quality of service. It encourages suppliers to deliver: (1) "simpler choices" by reducing the complexity and number of tariffs offered; (2) "clearer information for consumers;" and (3) "fairer treatment" which Ofgem encourages through clear rules, and enforces compliance with, through strict penalties.

There are performance obligations on supply companies to protect vulnerable consumers. Each company has to maintain a Priority Services Register (PSR), which is a list of disabled and chronically ill customers, and customers of pensionable age. Companies are required to provide certain non-financial services to their PSR customers.

2.2.2 Consultations

Ofgem has developed detailed guidelines on the approach it will take in consultations (Ofgem, 2011). For any consultation, it publishes a document that sets out the main issues, and that is available on its website. In order to facilitate inputs from even small consumers, Ofgem has

workshops and seminars for such consumers. In these efforts, it targets those consumers who are most likely to be interested in the subject of the consultation.

Ofgem launched the *Consumer First* program in 2007 to understand energy consumers better and develop “insights into their thoughts, behaviour and needs.” The program continues and complements the consultations through three activities:

- **Consumer First Panel.** It organizes workshops of 80 diverse domestic energy consumers to meet regularly and get the ordinary person’s perspective on “topical and challenging issues.” In the past, it has covered issues such as what information should be on bills, understanding of different types of tariffs, and understanding of the network companies.
- **Consumer Challenge Group.** This is a group of consumer experts to provide the consumer view during regulatory proceedings. In the words of Consumer First, this group acts as Ofgem’s “critical friend.”
- **Research.** Consumer First carries out its own research studies or commissions independent companies to do studies. In the past studies have been carried out on: consumer satisfaction with complaint handling processes of supplier; consumer experience with outages on electrical networks; supplier behavior and tariffs; and experience of vulnerable consumers.

While Ofgem’s main focus is on developing effective markets which it believes is the best strategy to reduce prices and ensure good service, it has developed an extensive and well considered approach consisting of consultations and panels to staying in regular touch with its consumers and incorporating their perspectives in its decision-making.

2.3 Australia

Electric utilities in Australia have been unbundled into generation, transmission and distribution, and retail businesses. The extent of deregulation and privatization varies across states and territories. The National Electricity Market (NEM) runs across Queensland, New South Wales, Victoria, South Australia and Tasmania as a connected grid. Generators sell into the NEM. There are smaller grids that serve areas outside the NEM, and these are managed by the respective state or territory (Australian Govt, 2014).

Electricity prices for households increased in real terms by 72% over ten years to June 2013 (Australian Parliament, 2014). This sharp rise created resentment among consumers against policy makers, regulators and energy supply companies (Houston, 2014). Consequently, the Council of Australian Governments (COAG) endorsed a package of energy market reforms developed by the Standing Council on Energy and Resources (SCER). Various initiatives have been developed to implement this package, named *Putting Consumers First*. This section focuses on two that are directly related to consumer involvement: (1) a strong stakeholder consultation framework as part of the better regulation reform package developed by the Australian Energy Regulator (AER); and (2) establishment of a national energy consumer advocacy body (CUAC, 2013).

2.3.1 Framework for Strong Stakeholder Consultation

2.3.1.1 Ongoing Consumer Engagement

In order to ensure that a network business (transmission or distribution) develops plans that are aligned with consumers’ long-term interest, it is required to engage with its consumers throughout the regulatory process. Even before a network business submits its proposal to AER, it must demonstrate “extensive and genuine community consultation” has taken place. AER has provided considerable flexibility regarding the engagement process, saying that the businesses are in the best position to develop a consumer engagement strategy. However, the engagement should be based on four principles: (1) clear, accurate and timely communication; (2) accessibility and inclusiveness;

(3) transparency; and (4) measurability. The network businesses are expected to identify cohorts and get their views; articulate the outcomes of the engagement processes and how they measure the success of their engagement; and periodically review and evaluate their consumer engagement process (AER, 2014; Reeves, 2013).

2.3.1.2 Stronger Consumer Representation in Regulatory Proceedings

Recognizing that ordinary consumers may find it difficult to participate in regulatory proceedings because of the technical nature and complexity of the issues, AER has established a Consumer Challenge Panel (CCP) consisting of thirteen consumer experts. It is expected that the CCP will give the consumer perspective on issues and thus help AER to come to a balanced decision. It is expected that CCP will advise on the following issues:

- Whether the network business's revenue proposals are justified by the services to be delivered; whether, and to what extent, do consumers want that service; and whether the proposals are in the long-term interest of consumers.
- The effectiveness of the process for consumer engagement followed by the network business, and to what extent, the consumers' views have been incorporated in the revenue proposals (AER, 2014).

2.3.2 Establishment of a National Energy Consumer Advocacy Body

Energy Consumers Australia Ltd (ECA) was established on 30th January 2015 with the following objective:

'To promote the long term interests of consumers of energy with respect to the price, quality, safety, reliability and security of supply of energy services by providing and enabling strong, coordinated, collegiate evidence-based consumer advocacy on national energy market matters of strategic importance or material consequence for energy consumers, in particular for residential and small business customers.' (ECA, 2015)

ECA's focus will be on market (NEM) issues, particularly from the perspective residential and small business consumers. In addition to participating on these issues, ECA will also: communicate and engage with consumers and consumer groups; help develop capacity for consumer advocacy; and undertake or support research to develop an evidence base for advocacy on consumer-related policy issues (ECA, 2015).

2.4 Brazil

The Brazilian constitution, introduced in 1988 as part of the transition to democracy, sanctioned decentralization of policy-making and included mechanisms for citizens to participate in policy formulation and monitoring. In keeping with this characteristic of institutions in Brazil, the Brazilian Electricity Regulatory Agency, ANEEL (*Agencia Nacional de Energia Electrica*) provides several avenues for the public to participate in the electricity sector, such as public hearings and public consultations (ANEEL, 2014).

One unusual approach to participation is the use of Electric Power Consumer Councils. Each distribution licensee has a council with one member from each category of consumers: residential, commercial, industrial, rural and public power, nominated by civil society organizations. While resources for a council are provided by the respective licensee, the members of the Consumers Council develop their own strategy and associated work plan. In addition, the Consumers Council also designs projects to use money collected through fines to benefit consumers. Consumers can voice their concerns about their electricity service through their representatives on these councils.

How well have these mechanisms worked? There is not much information available in English on this matter. However, a study on public hearings at ANEEL provides some interesting insights. It examined public participation in several public hearings for a tariff review, and found that

participation was dominated by the regulated entities, with the number of participants from the regulated entities being twice that from participants (Castro, 2013). The participation was skewed even more when the hearings were focused on more technical subjects such as the methodology. Castro found that consumer representatives played a very weak role. They have “a limited ability to empower social voices and address complex issues.” She notes that, “Indeed, public hearings alone cannot promote social participation.” Therefore, she recommends strengthening of consumer groups and assistance to individual consumers so that they can be better prepared and can participate more effectively in hearings. She points to another trend that is seen in India also; misuse of public hearings by politicians and consumer groups by using them for self-promotion, politicking and increasing conflict.

A review of the regulatory reform in Brazil by OECD echoes the concerns of Castro regarding the effectiveness of participation (OECD, 2008). While the observations refer not only to the electricity sector, it found that in spite of access to means of participation, “...effective participation of citizens in consultation procedures remains a challenge. Social participation is low as civil society can be difficult to represent. There is also a need to build up a voice for consumers.”

3. The State of Grievance Redressal and Consumer Protection in Indian Electricity

The issue of consumer protection dates back to the emergence of trade and commerce. However, until the Consumer Protection Act of 1986, India did not have any systematic movement for safeguarding consumer interests.

Over time, with increasing coverage and complexity of markets, especially as an outcome of liberalization and restructuring of key economic sectors, and rise in consumer awareness, organizations that handled dispute redressal under this Act, became gradually over loaded with cases and an there was an increase in pendency. With technical advancement in goods and services provisioning, redressal of disputes among providers and consumers in some sectors required technical knowledge and expertise, creating a need for specialized agencies. Consequently, as an outcome of structural reforms, specialized grievance redressal mechanisms were institutionalized in some of the key public service sectors, including electricity.

This section first provides an analysis of the structures and processes of consumer grievance redressal in Indian electricity, and how they have evolved. Subsequently, drawing on analysis of documents, consumer surveys and stakeholder interviews, it assesses their effectiveness in the five states.

3.1 The Legal and Institutional Structure of Grievance Redressal in Indian Electricity

The Electricity Act of 2003 makes mandatory provisions for establishment of institutions for consumers’ grievance redressal and provides broad guidelines on their composition and functions.

Box 3: Key Provisions in the Electricity Act 2003 for Consumer Protection

Sec 57: Standards of performance of licensee

- To be specified by the concerned Commission after consultation with the licensee and persons likely to be affected.
- On failure to meet the standards, licensees are liable to pay compensation to affected parties, within 90 days
- Different standards of performance for a class or classes of licensees (Sec 58)
- Periodic compliance and compensation paid report to be filed by the licensees, which will be published annually by the appropriate Commission.

Sec 42 (5-8): Establishment of Consumer Grievance Redressal Forum (at least one by each distribution licensee) and Ombudsman (at least one at state level) for redressal of consumer grievances, within a specific timeframe and in a defined manner, as may be specified by the state commission.

Sec 110-124: Appellate Tribunal for Electricity

Any person aggrieved by an order made by an adjudicating officer under the Act or an order made by any of the Commissions may appeal to the Appellate Tribunal. If not satisfied with the order of the Appellate Tribunal, the person may appeal to the Supreme Court (Sec 125) [Approachable by both the consumers and utilities]

(See Box 3 for the key provisions in the Act for consumer protection.) Beyond these requirements, the central legislation does not provide any further detail on the composition or functioning of the institutions for grievance redressal. One advantage of this lack of detail is that considering the political economy of states differs widely across India, it creates an opportunity for the State Electricity Regulatory Commissions (SERCs) to set the rules and regulations tailored to the local context. On the other hand, it leaves the SERCs with some degree of ambiguity, and opportunity for maneuvering to accommodate interests, agencies and institutions. Consequently, the resulting structures and processes vary across states. While some SERCs have been proactive and responsive to consumer demands and interests, others seem to maintain a soft corner for state-owned utilities, and some are submissive to state governments.

All the five states covered in this study have established consumer grievance redressal mechanisms for electricity consumers. Both the Consumer Grievance Redressal Forum (CGRF) and Ombudsman are institutionalized as quasi-judicial bodies. CGRFs are set up and directly supported by the discoms, while the Ombudsman is set up and supported by the respective SERC. The CGRF is a three member body with varying composition across the states, while the latter is a single member body.

In all the states covered in this study, grievance redressal is carried out through a four-tiered mechanism. First, any consumer with a complaint must contact the respective discom and go through the internal complaint handling process of the discom. If the consumer is dissatisfied with the response or the complaint is not addressed in the stipulated time, the consumer can approach the second level of redressal, the CGRF. If the consumer is not satisfied with the outcome at the CGRF level, he/she may appeal the CGRF's decision to the Ombudsman, the third level. If still dissatisfied, the consumer has the choice of approaching the High Court against the decision of the Ombudsman (See Figure 1). At each level, except the judiciary, the responsible authorities are required come to a solution or judgement within a specific time, as prescribed by the respective SERC in its regulations.

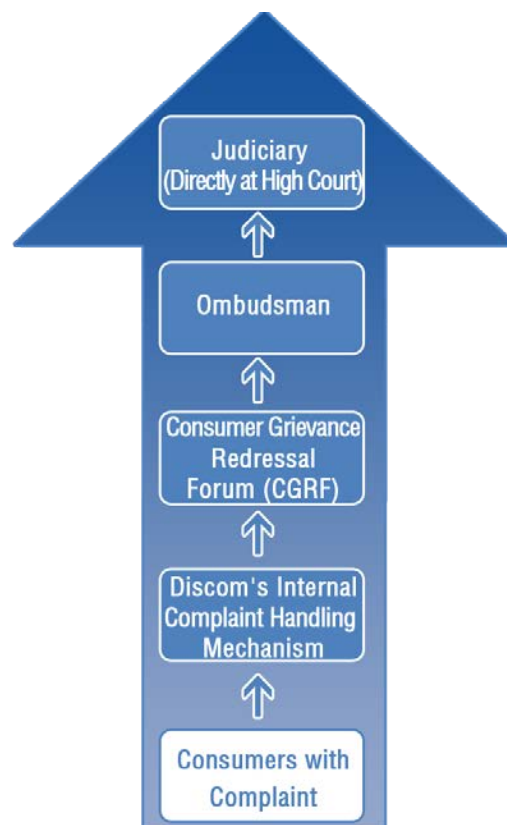

Figure 1: Four Stages of Consumer Complaint/Grievance Redressal

While the basic institutional structure remains similar across the states, there are significant differences in the details of the structure and the processes for grievance redressal. Some states have endeavored to bring the grievance redressal mechanism closer to consumers by setting up multiple CGRFs within a discom (at district level in Karnataka or at the zonal level in Maharashtra) or by having a mobile CGRF (in Haryana) or a complex web of hierarchical mechanisms covering each and every administrative unit (in Rajasthan). Further, the composition and independence of these agencies differ across states. In all cases, the CGRFs and Ombudsmen are required to submit a periodic report to the respective SERCs. The process of grievance redressal has evolved differently in different states.

3.2 Varying Evolution and Practices across States

3.2.1 Composition of the Forums

While all states have single member ombudsmen and three members CGRFs, the composition of CGRFs and appointment of members vary across states. All three members in Delhi are independent of the respective discom, Maharashtra has one member from the discom, Karnataka and Haryana have two members from the discom, and all the members in Rajasthan are from the discom. This has serious implications for the independence of the forum. The presence of even a single member from the discom and appointment of the Chairperson by the discom is seen as anti-consumer by some civil society advocates in Maharashtra. In other states, it was found that when two or more members are drawn from the discom, and thus constitute a majority, the forum tends to be pro-discom. The impact of having one or two members from the discom in the CGRF can be seen in the number of cases being decided in favor of the consumers. For example, while Delhi CGRFs have decided 70-80% of the cases in favor of the consumer, Maharashtra CGRFs have decided 62% of cases and Karnataka CGRFs have decided only 20% of the cases in favor of consumers. Second, some of the CGRFs have a legal member or have a Chairperson with a judicial background, resulting in a system that often becomes too legalistic to the detriment of consumers. In such cases, rather than deciding only on the merits of the case, the way a case is presented also plays a role in the final decision.

3.2.2 Legalistic Process

Presence and intervention of legal professionals in the system, particularly in cases where a large amount of money is at stake, have fostered legalistic developments with a focus on the quasi-judicial facet of these forums. In many cases, the complainants engage professional lawyers to represent their cases in forums, even though this is not required. It was also pointed out that some CGRFs make decisions based solely on the petition by the complainant, in a legalistic manner, without consideration of evidence and interpretation that the complainant may not be aware. For example, in one case the CGRF did not recommend compensation to the complainant just because he did not ask for it in his petition, even though he was eligible. Though the system is yet open and many of the CGRFs accept grievances through a plain application, there is a concern that further legalization of the process may make it inaccessible to small consumers.

3.2.3 Adequacy of Resources for CGRF

The states also vary in the availability of resources for the CGRFs and Ombudsmen. While Delhi seems to be doing well by having separate offices and staff for both CGRFs and Ombudsman, in other states, CGRFs have their offices located within the discoms and Ombudsmen with the SERC. This could have significant implications for independence of the forums and their responsiveness to the consumers. Moreover, the salary of CGRF members are decided and drawn from the discoms directly, except in Delhi. The operational expenses of the Forums are also drawn from discoms' accounts and do not have any separate allocation. Consequently, the Forums have been dependent on the discoms in meeting their operational needs and tend to be loyal to them. To a great extent, it is reflected in the outcomes, the number of cases being decided in favor of the consumers. During

in-person interviews in this study, it was found that the CGRFs and Ombudsman in Delhi had a more consumer-friendly attitude and tried to address subtle issues to build consumer trust in the system.

3.2.4 Nature of Grievances Considered

There appears to be a greater emphasis on grievances related to billing and other monetary issues in the grievance redressal mechanism. Except Delhi and Maharashtra, all other discoms accept only those grievances where monetary issues are involved. Consumers with grievances on the quality of supply and service in these states are left to the mercy of the discom staff. On most occasions, such complaints in quality of service or discom performance are either directed to the concerned local utility office or the consumers are simply asked to consult with the concerned local office. Consequently, there seems to be an emerging consumers' apathy towards the system. In case of Rajasthan, this has led to an interesting trend where the consumers approach other administrative agencies and political offices for addressing the quality of service complaints. A growing number of cases are being reported to official and political authorities, such as the district magistrate's office, local MLAs and even the Chief Minister's office. This also shows declining public trust in the grievance redressal mechanism.

3.2.5 Monitoring of Compliance with Grievance and Service Quality Related Regulations

The study found that the Standards of Performance (SoPs) set for the discoms are not used to their full potential. Almost no credible mechanism exists to monitor compliance with SoPs, and neither do the grievance redressal forums consider these as a factor while taking decisions. Delhi seems to be the only case where CGRFs have considered SoPs and recommended compensation to the consumers. Unfortunately consumers too do not have much awareness and information on the SoPs, and therefore, do not seek compensation in their complaint for the discom failing to meet its SoP. The SERCs also do not seem to take performance of the utilities relative to the SoPs into account in their regulatory decisions.

Compliance with CGRF and Ombudsman orders by the discoms is an issue of concern. For example, in Maharashtra, discoms' compliance with CGRF orders declined from 83 percent over the period 2005-2009 to 44 percent in the year 2012-13 (MERC, 2010; MERC, 2014). Given that CGRFs and Ombudsmen have no enforcement or penal powers over the discoms, they cannot do much to ensure compliance. Though consumers can take up this matter at the regulatory commission level, it becomes another hurdle for consumers.

Furthermore, not much has happened at the commission level and the commissions have not taken up the issue of compliance on a *suo moto* basis. All the five states have regulations that require the CGRF and Ombudsman to file periodic reports with the respective Commission. The Commissions should ensure that the CGRFs and Ombudsmen comply with these requirements. Further, the Commissions can and should require the reports to include data on whether or not each decision has been complied with by the respective discom. The Commissions must hold meetings with the CGRFs, Ombudsmen and the discoms to discuss the performance according to these reports, as was being done in Delhi. Ideally these meetings should combine a discussion of the reports on performance of discoms relative to the SoPs, which they should also be required to file with the respective Commissions. In Maharashtra, the regulations specifically permit the Commission to initiate proceedings, *suo moto* or on the filing of a complaint, to impose a penalty or initiate prosecution proceedings for non-compliance with orders of a CGRF or Ombudsman. The Commission should also include information on poor quality of service or non-compliance of CGRF or Ombudsman orders in its decisions on tariff-setting, by carefully scrutinizing and limiting allowance for expenditures on quality of service if so warranted by poor performance. Unfortunately, none of the commissions have used such provisions to penalize the discoms. Consequently, an important component of consumers' voice, expressed in the form of individual grievances against utility performance, is lost instead of being amplified at the level of regulatory decision-making.

3.2.6 Improving Consumers' Awareness

Consumer awareness of the grievance redressal system appears to be low. Though all the discoms have put some effort towards increasing awareness, again to a varying degree, there are still significant gaps. The responsibility of consumer awareness often rests with the discoms, except in Maharashtra where it is assigned to the CGRFs.

It was observed that most of the discoms aim to merely meet the awareness requirement only in letter, not in spirit. Most discoms publicized the CGRF's existence by occasional advertisements in newspapers, officious in tone. In some cases, these advertisements were published early on, but have now been discontinued. Any significant innovation in informing and communicating with the consumers was not noticed. From a random sample of consumers, about 22% of the respondents (highest 44% in Haryana) did nothing when they faced a problem. Most of them did not approach anyone because either they did not know whom to approach or they did not have any trust in the system. A survey of consumer awareness of their rights and consumer grievance redressal within the service territory of Maharashtra State Electricity Distribution Company Limited (MSEDCL), commissioned by Maharashtra Electricity Regulatory Commission (MERC), found abysmally low level of awareness. Of a sample of 12,177 consumers, only 71 (less than 1 percent) knew about the Electricity Act 2003 or the rights of electricity consumers. Of these 71, only four knew about the CGRF and Ombudsman regulations (MDRA 2013).

3.2.7 Discoms' Internal Complaint Handling

Even for those who are aware of the CGRM, going through a multi-stepped process to get satisfactory resolution of a grievance can become a tedious experience. In some cases, even the internal complaint handling process in the discom can have many steps and can be complex and tedious. Some examples are the internal grievance redressal process in Maharashtra (MSEDCL) which itself has many hoops that the consumer has to jump through and until recently Rajasthan, where the CGRFs themselves had a four layered structure. It is important and useful to have more than one avenue to resolve grievances, but it would be much better for the consumers if the first level (discom's internal complaint handling) were more effective and efficient so that the consumer does not have to go through a tedious experience. This would also save resources, time and effort on behalf of the consumer and the utility. The current state of internal complaint handling varies across states and discoms: discoms in Delhi and in Mumbai have to a great extent improved the internal complaint handling, though more is desired; discoms in Karnataka and Haryana are in the course of improving the process and consumer experience; but, not much has been done in Rajasthan or MSEDCL area in Maharashtra.

3.3 Summary of Status of Grievance Redressal in the Five States

Even after two decades of reforms and more than a decade since the enactment of the forward-looking Electricity Act of 2003, electricity consumers in India are still facing a range of problems in the service, including power supply interruptions, incorrect meter reading and billing, faulty meters, load and connection issues (Figure 2 provides the share of consumers who faced different kinds of problems with electricity service). While the CGRF and Ombudsmen offer a useful platform for addressing these issues and improving consumers' experience with service delivery, precious little has been achieved through them. In most cases, consumers lack awareness on available avenues for redressal and their rights. Many of those who have been able to voice their concerns are not satisfied with the outcomes (See Figure 3 for percentage of respondents satisfied with CGRF decision). At the same time, many consumers are apathetic to the existing mechanism and do not report their dissatisfaction with the service. Figure 4 provides the share of respondents in the selected five states who did not approach any one when faced with any problem. Consequently, while consumers recognize some improvements in service quality in recent years, it has not resulted in significant improvements in consumer experience. Except in Karnataka, where the discoms are

currently working to improve consumer interaction, the level of consumers' satisfaction with service quality improvements in the last five years was found to be significantly low (See Figure 5).⁵

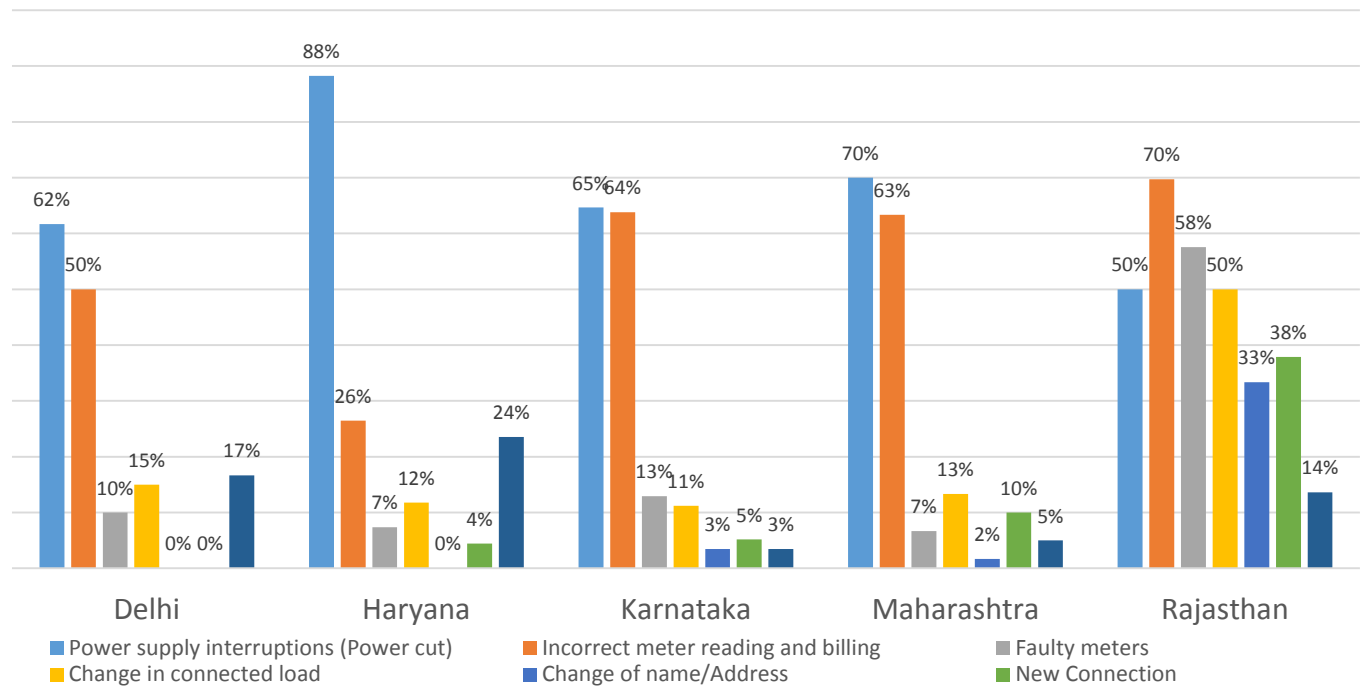

Figure 2: Types of Problems Faced by General Consumers (in last 2 years)

⁵ In case of Karnataka, where consumers' satisfaction with service quality improvements in recent years is significantly high, this could be attributed to the discoms' reforms in consumer complaint handling and interaction currently underway. The discoms have taken innovative initiatives to use ICTs and social media to interact with consumers, which is proving effective. On the contrary, satisfaction with CGRF decisions is lowest in the state. This may be attributed to composition of the forums in the states, with higher presence of discom staff (two out of three members), and resulting bias in deciding the cases. Moreover, Karnataka is one of the cases where non-monetary complaints are not considered by the CGRFs.

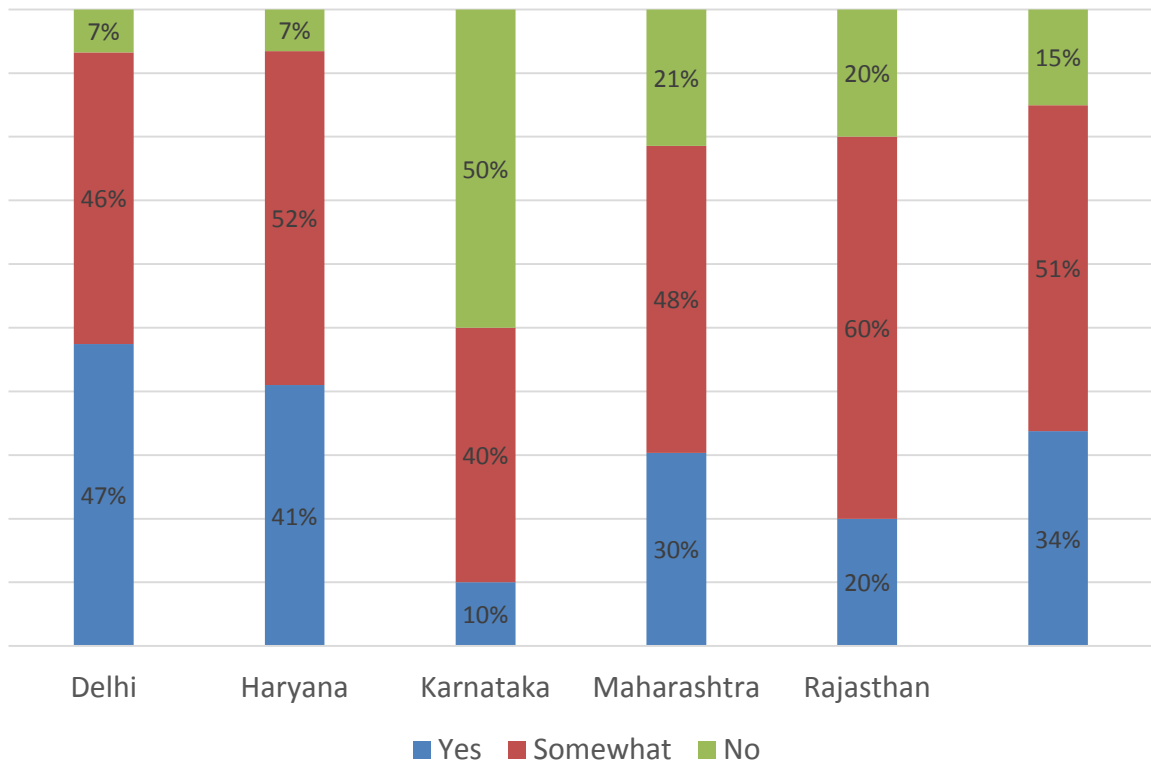

Figure 3: Share of Consumers Satisfied with CGRF Decisions

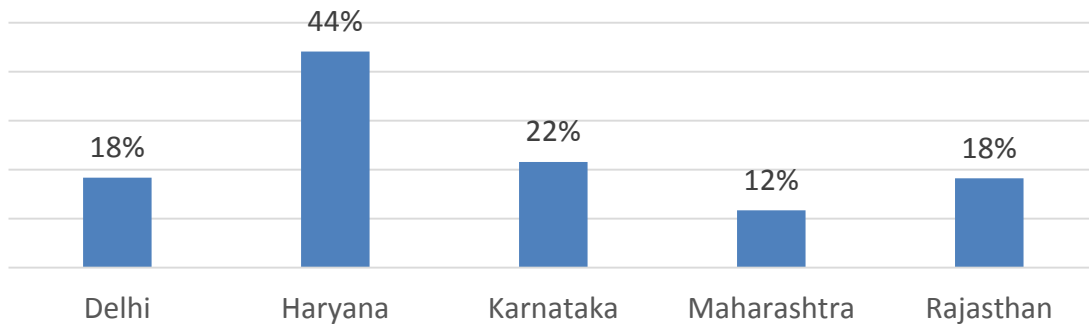

Figure 4: Percentage of Consumers who did nothing when they faced any problem in electricity service.

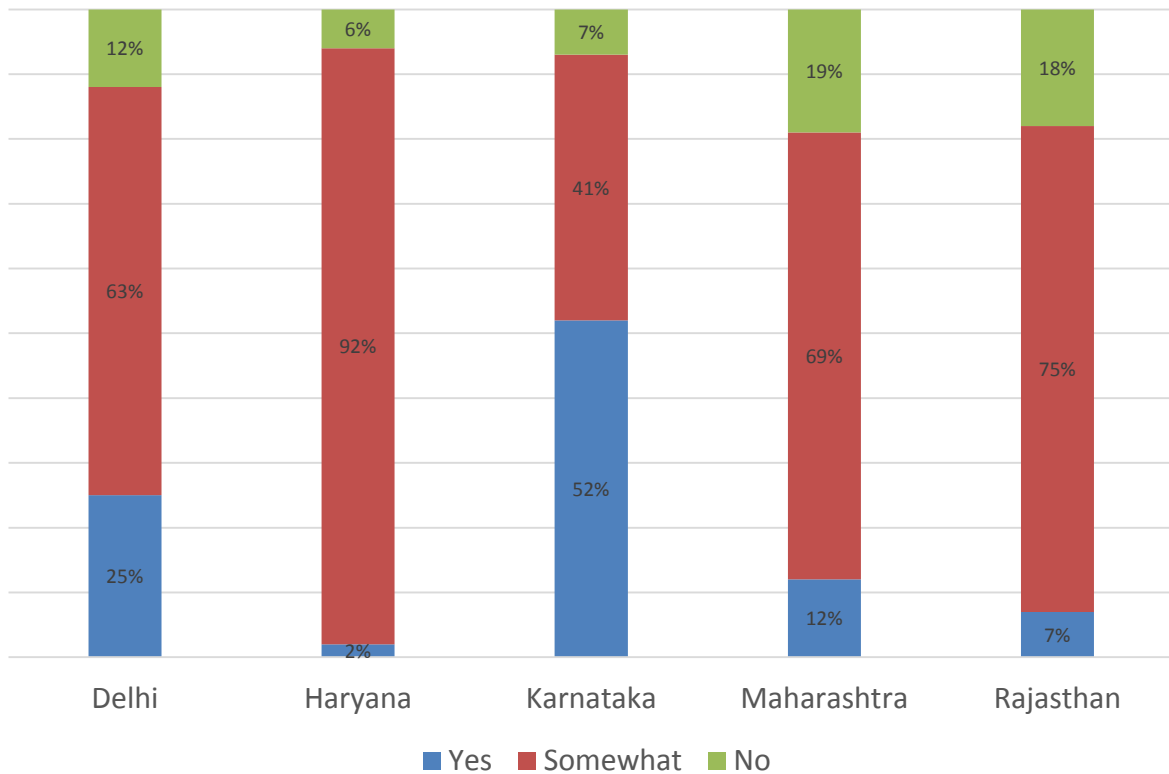

Figure 5: Consumer Opinion on Improvement of Service Quality in Last Five Years

In conclusion, the grievance redressal mechanism in electricity has emerged as a useful platform for the consumers to raise their voice, question the performance of utilities, and hold them accountable. However, the CGRM has not reached its potential for effectiveness as yet. The CGRM provides a great opportunity to improve consumer experience and overall governance of the sector. The states can learn from each other's experiences in instituting CGRMs. The concluding section of this paper provides detailed recommendations and a roadmap for improvement of grievance redressal mechanisms.

4. Consumer Participation and Representation in the Regulatory Process

The Electricity Act is the main piece of legislation that governs the operation and management of the electricity sector in India. It has several provisions for inclusion of consumer voice in regulatory decision making. On issues related to determination of tariffs and licensing, the concerned commission is required to publicize the application in a manner that it is available for public access and comment, and is required to consider all suggestions and objections received from the public before deciding on these issues (Electricity Act, 2003: Sections 15, 18, 62 and 64). Furthermore, the concerned Commission may authorize any person, as it sees fit, to represent the interests of consumers in the proceedings before it (Electricity Act, 2003: Section 94)⁶.

In addition to these provisions for direct participation by consumers, the EAct provides for the formation of State Advisory Committees (SACs) as another avenue for inclusion of various perspectives in regulatory decision-making. The SACs, with representation from a diverse mix of interests, are supposed to advise the Commission on major issues of policy, issues of quality of

⁶ An amendment currently being proposed would mandate that the commission authorize such a consumer representative (The Electricity (Amendment) Bill, 2014).

service, compliance by discoms of license conditions, protection of consumers, and standards of performance for discoms.

4.1 Assessment of Participation in the Five States

The institutional framework has been put into place in all the states, but given the variations in the political economy and political sociology of the states, there are significant differences in institutionalization, institutional processes and consequently, in the level of consumer involvement in the electricity regulatory process. Considering that one of the main functions of SERCs is to set tariffs, and the sensitivity of consumers to tariff issues, the study focused on regulatory proceedings around retail tariff fixation. In order to assess changes in consumer involvement over time, orders and record of proceedings in the last five tariff proceedings in each state were reviewed. The functioning of the SACs in all these states was also analyzed to understand their effectiveness in representing consumer interests in the regulatory process.

4.1.1 Level of Participation

There are two main avenues for consumer participation in tariff related regulatory proceedings: (1) participation in public hearings; and (2) submission of written comments/objections to the SERC. The orders of the SERC in Haryana and Karnataka do not provide a list of participants in public hearings, and Maharashtra does not provide a list of people who submitted written comments. Keeping these limitations in mind, this section discusses how effectively these two avenues for consumer participation are being used in the five states.

The total number of electricity consumers in a state was used to normalize the results for variations in the size of the states. Looking at Table 2 and Table 3 together, one can see that Maharashtra has seen the highest level of participation, reaching an astounding level of over 1,100 participants per million consumers, corresponding to over 24,000 participants in public hearings. Not all these participants spoke at the public hearings, but they were present and handed in comments to show endorsement of what was presented verbally by others in their group. Unfortunately, the level of participation dropped dramatically in 2012 to 19 participants. Box 4 explores some of the reasons for this precipitous decline. Next in order of strong consumer participation is Delhi which has a reasonably high level of participation. Haryana and Rajasthan have abysmally low levels of participation; however, the participation in Rajasthan has been increasing over time. Karnataka is marginally better, but the participation levels have been dropping over time. Some of the state specific details regarding participation are presented in Table 2 and Table 3.

Table 2: Number of Participants per Million Consumers

State	2007	2008	2009	2010	2011	2012	2013
Delhi	27	34		35		32	56
MH	486	179	570	1115		19	
RJ	0.2			1	3	3	4

Table 3: Number of Written Submissions per Million Consumers

State	2007	2008	2009	2010	2011	2012	2013	2014
Delhi	64	97		94		32	56	
HY				5	4	5	4	3
KT			43	12	19	5	7	
RJ	0.3			0.5	8	8	6	

Notes:

i. Discoms considered in this table: BESCO, HESCO, GESCOM, MESCOM, CESC

- ii. For Maharashtra, data only for the publicly owned MSEDCL used; it provides almost 85 percent of the electricity in the state.
- iii. Most recent estimate of number of consumers in each state applied to all years.

4.1.2 Composition of Participants

There is wide variation not only in the level of participation, but also who participates in public hearings, and the issues that on which they focus (Figures 6 and 7). In general, large consumers are better informed and organized to represent their views in regulatory proceedings. Civil society organizations or consumer groups to represent small consumers are either non-existent or struggling, except in Maharashtra.

At one extreme, there is Haryana which does not have a single consumer group that works on electricity service, although there are a few groups which work actively in other public service delivery sectors. A member of a consumer group that works on telecom and health services complained that the Haryana Electricity Regulatory Commission (HERC) is not interested in engaging with consumers or consumer groups.

In Rajasthan, most of the participation comes from larger consumers. There is a clear absence of consumers groups representing small consumers or the broader consumer interest. To the limited extent that small consumers participate, their intervention is focused on demands for lower tariff. However, there are a few public citizens who have been intervening and participating regularly and have provided substantive recommendations. Interestingly, all these people are retired officials of the erstwhile Rajasthan State Electricity Board and they tend to speak from the utility perspective, though their recommendations are constructive and targeted at system improvement. Consequently, the consumers' perspective, especially the small consumers' interest, is clearly missed in the regulatory governance. A new Chairperson of Rajasthan Electricity Regulatory Commission (RERC), with experience from Karnataka Electricity Regulatory Commission (KERC), was appointed in early 2014, and it is encouraging that he has a vision to promote consumer participation and improve consumer interaction with the Commission.

While Delhi does have many vibrant and assertive civil society or consumer organizations, not many have participated in regulatory proceedings on electricity service issues. There are a few smaller Civil Society Organizations (CSOs) that have been participating in these proceedings, but mostly on tariff issues. The uniqueness of Delhi is the presence of a significant number of Resident Welfare Associations (RWAs) who have been consistently engaging in the regulatory process and are reasonably well-informed on technical issues. At the same time, there are several individual participants who have technical expertise in the sector. Consequently the deliberation and issues raised in hearings in Delhi demonstrate that the participants are relatively well informed. The number of issues raised in the latest tariff hearing is significantly higher than in other states (See Figure 7). Engagement by informed stakeholders is also reflected in the nature of issues discussed: about 40 per cent of the issues were on the performance of discoms followed by other procedural issues and tariff issues. Having fewer issues on quality of supply may be a reflection of significant improvements following privatization of the distribution business.

Karnataka has enthusiastic CSOs and consumer groups, which are relatively informed and assertive compared to all other states, except Maharashtra. However, for these groups representing small consumers, lack of technical expertise and resources has been a hindrance to engaging vigorously in the regulatory process. In contrast, industry groups are well organized and have adequate resources and knowledge. They have been engaging regularly and consistently on issues of relevance to high transmission consumers. One of the leading industry groups has even challenged the decision of KERC in the High Court.

Box No 4. The Rise and Fall of Consumer Participation in Maharashtra

Maharashtra has been the birthplace of many social movements; a spirit of social activism prevails in the state.

In keeping with this reputation, Maharashtra was, until recently, a shining example of consumer participation in electricity regulation. The level of participation in the hearings on tariff determination for the largest discom (MSEDCL) has been astonishingly high (see Table 2). At its peak in 2010 it reached almost 25,000, several orders of magnitude higher than any of the other states. Even at its lowest in 2012, it was much higher than the other states.

There are several reasons for this enthusiastic and effective participation:

- A group of dedicated and capable consumer groups. The initial group consisted of four organizations: Mumbai Grahak Panchayat; Prayas Energy Group; Thane-Belapur Industry Association (TBIA); and Vidharbha Industry Association (VIA).
- These groups were willing to look beyond their own interests and advocate in the general public interest. For example, in the first tariff order, rather than focus on reducing category-wise tariffs, the consumer groups advocated reducing T&D losses. There continues to be strong cooperation and networking among them, further enhancing their effectiveness.
- The early group of regulators were very receptive. They encouraged the participation of consumer groups and responded to their suggestions. In the words of one of the early participants, this bolstered the confidence of consumer groups that they were saying something useful. This encouragement was critical in the nascence of these groups and regulation in the state.

In accordance with the E Act, which empowers a commission to authorize any person to represent the interests of consumers in proceedings before it, MERC appointed a group of 'authorized consumer representatives', who were invited to represent consumer interest in all kind of regulatory deliberations. Initially, the commission had only four such representatives, as listed above. Later, the number was increased to about twenty. Other initiatives of the Commission included local hearings to facilitate consumer access to such hearings. Thus, in the early years after MERC was established, Maharashtra provided a healthy eco-system for consumer participation satisfying all three of the key requirements: assertive and capable consumer groups; receptive SERC; and a non-interfering government.

Unfortunately, consumer participation in Maharashtra is losing much of its sheen. The decline started with the state government attempting to influence MERC decisions and publicly criticizing the Commission members (for example, see (ToI, 2011)). This hostility not only interfered with the smooth functioning of the Commission, but also damaged its legitimacy. Now, the Commission too is no longer seen as supportive of consumer participation, instead it is seen as being anti-consumer and pro-utility. Space for consumer participation has shrunk with even the Appellate Tribunal for Electricity (ATE) expressing its disapproval of the neglect of the consumer voice by the Commission (ATE, 2014). A healthy relationship between civil society and the Commission has been replaced by acrimony with some consumer groups asking for the removal of the Chairperson of the Commission (MVGS, 2014). So two pillars of the required eco-system for consumer participation (supportive SERC and non-interfering government) have collapsed, effectively silencing the consumer voice. The regulations regarding the selection of consumer representatives (CRs) will lead to weakening of the CRs, seriously damaging the first pillar (assertive and informed consumer groups) of the supportive eco-system required for effective consumer participation. Thus, over time, all three pillars of the eco-system have collapsed or are in serious danger of doing so. This is a major loss, because the benefits of effective consumer participation had been demonstrated in the early years of MERC. The decline in consumer participation in Maharashtra is a serious matter of concern and shows that even a relatively well running system can turn dysfunctional, if the required eco-system is allowed to deteriorate. In the concluding section of this paper, there is a discussion of the need for ongoing evaluation of systems for consumer protection and participation that may help avoid such situations.

In contrast to the other states, Maharashtra has until recently had very effective consumer participation. Several years back MERC appointed a group of 'authorized consumer representatives', who were invited to represent the consumer interest in all kind of regulatory deliberations. At that time, the commission had only four such representatives. These four groups are dedicated and informed and focus on the larger public interest and have provided valuable inputs to the Commission. Later, the number was increased to about twenty. Other initiatives of the Commission have included local hearings to facilitate consumer access to such hearings. Considering the large geographical coverage of MSEDCL, the hearings for MSEDCL tariff determination were held in six

different locations across the state. For more details, please see the Box in this section on “The Rise and Fall of Consumer Participation in Maharashtra.”

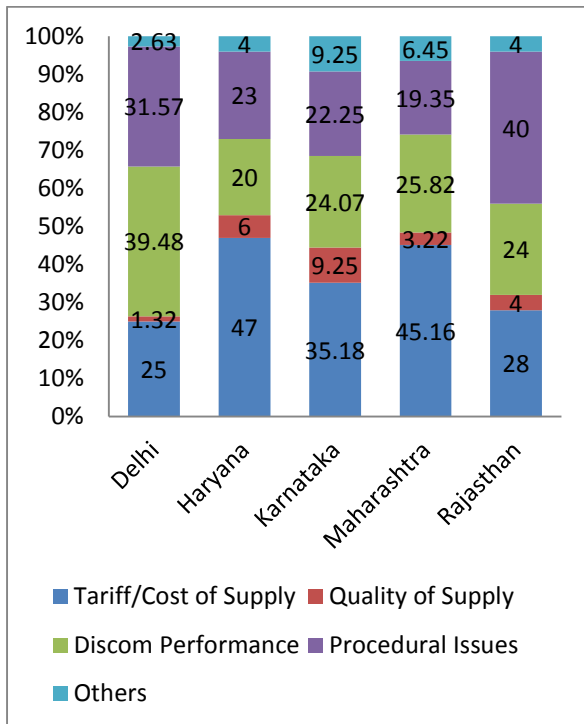

Figure 6: Nature and Share of Issues Raised in Latest Retail Tariff Hearings

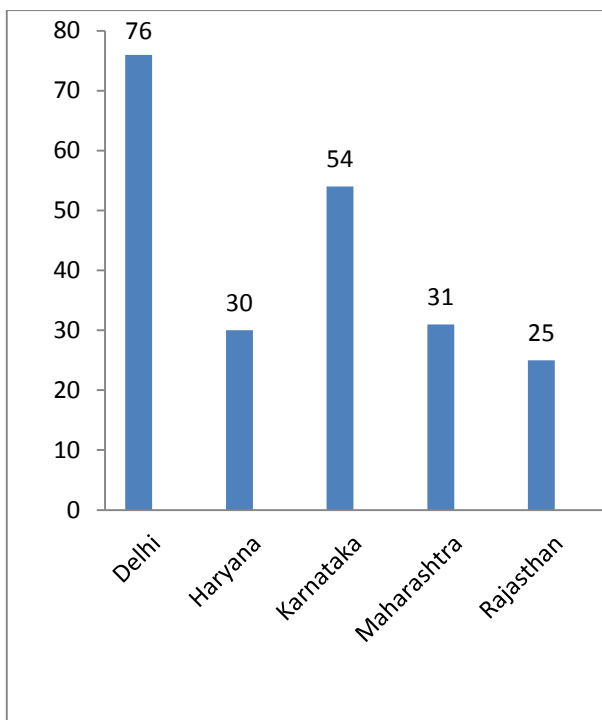

Figure 7: Number of issues raised in the latest retail tariff proceedings

4.1.3 State Advisory Committees (SACs)

An SAC can be a useful instrument to include diverse perspectives, including that of consumers, in regulatory decision-making. However, this potential of SACs has been under-utilized in the five states. The composition of the SACs has been skewed in favor of the government and discoms.

Moreover, the SACs focus more on operational issues and not much on major policy issues. As with other aspects of consumer protection and participation, there is wide variation between the states in the composition, functioning and effectiveness of the advisory committees.

Consumer interest representation through the SACs has been quite effective in Delhi. The SAC of Delhi Electricity Regulatory Commission (DERC) has been performing better than in the other four states. The Delhi SAC has the highest number of subject experts and no representation from the discoms or licensees, although, the number of consumer representatives is comparatively low (see Table 4). The SAC meets at least twice a year to deliberate and advice on important issues. However, the Commission has not been very regular in putting up the minutes of such meetings; minutes of only two meetings in 2011 are available on the DERC website. A review of those minutes indicated that the committee has taken up substantive issues for deliberation, with wide implications for consumers (see Table 4). According to an SAC member, the Committee has guided the Commission on important policy matters. The Commission has also appointed SAC members on some internal committees to assess important policy issues. The Commission has been quite receptive to suggestions by the SAC, however, that receptivity depends to some extent on the Chairperson; some of the DERC Chairpersons, as ex-officio Chair of SAC, have been more receptive than others.

In contrast, consumer interest representation through the SAC in Haryana has been largely ineffective. Though the SAC in Haryana has the highest number of consumer members in the committee, it also has four representatives from the licensees (see Table 4). The SAC meetings are held regularly, but merely as a ritual to meet the provisions under the legislation. An SAC member claimed that these meetings are essentially driven by the discom representatives stating, "The experience has been so frustrating that we are no more attending these meetings." It was also claimed that the regulators are sympathetic to the discoms in these meetings. HERC has not put up minutes of any of the SAC meetings, making it difficult to determine the kind of issues that were discussed in the meetings.

The SAC in Karnataka has been more effective. On the positive side, the Committee has more than one-third of the members representing various consumer interests, but on the down side, it has a high representation from the licensees. There are four members from the licensees and other licensees are also invited to the SAC meetings.⁷ SAC meetings are held at regular intervals and well attended. A review of the minutes of the most recent meeting indicates that the issues discussed were substantive and had a focus on consumer interests (see Table 4). In spite of this and though there is not the cynicism prevalent in Haryana, the general perception is that the SAC has not been as effective as it could be. The Commission listens to all sorts of suggestions on matters like power purchase, quality of supply, tariff and investment, but it rarely acts. As an SAC member asserted, "the Commission reacts fairly to the suggestions... [but it] should respond faster to suggestions." He also added that the Committee members have good experience and knowledge on the subject and the members work cooperatively. What is needed is prompt response and action on the suggestions made to the Commission.

In Maharashtra the SAC has been established and until about a year and half ago was meeting regularly. The composition of SAC is well balanced with seven consumer members and four experts (see Table 4). However, it has not been very effective. Until June 2013, the SAC in Maharashtra was meeting at frequent intervals. But there have been no meetings since then. Even when the meetings were held regularly, participation by members was very low. In the later meetings, the level of participation was as low as 2-5 members out of 20 members. As a result, the substance of deliberation has also been affected. The minutes of the most recent meeting (26th meeting) of the

⁷ KERC has appointed representatives to the SAC from two of the discoms (BESCOM & GESCOM), along with KPTCL and KPCL. However, representatives from other discoms are invited to SAC meetings.

SAC had only two presentations: one on transmission and the other on smart grid road map, and was attended by three members only. Some interviewees pointed out that the SAC has facilitated coordination between different government agencies on matters such as Right of Way, digging of road and laying of wire. However, the SAC has not been able to provide much substantive advice. It has failed to provide a venue for the development of a vision for the electricity sector in Maharashtra, and of course now it has been dormant since June 2013.

RERC has constituted an SAC, but the functioning of the Committee is not at all effective. By composition, the SAC seems to be pro-utility and pro-government; in a 20 member Committee, there are only two consumer members, but six licensee members and another six representatives from various government departments. Though some of the SAC member, particularly the experts, have some good ideas for system improvement, they complain that the Commission is not ready to listen to them. The SAC meetings are held regularly, but seem to be a mere ritual. Moreover, the minutes of the recent meeting suggest that there was more discussion on procedural issues than on substantive issues (see Table 4). However, in spite of the adversities, the SAC members claim that they have been successful in pushing through some reforms in the grievance redressal mechanism: a) appointment of an independent Ombudsman, b) appointment of an independent member in corporate level CGRF, and c) allowing the consumer complainant to move to Ombudsman directly after approaching any one level of the CGRF.

Table 4: Composition of State Advisory Committees

	Delhi	Haryana	Karnataka	Maharashtra	Rajasthan
Total No of Members	19	21	16	20	20
Consumer/Consumer Group Members	5	9	6	8	3
Expert Members	6	1	5	4	3
SERC Members	3	3	--#	4	3
Government Representatives	5	4	1	4	5
Licensee Members	0	4	4*	0	6
Others		0	0	0	
	<ul style="list-style-type: none"> . DERC (3) . Principal Secretary (Power), GNCTD (1) . Department of Food Supplies and Consumer Affairs, GNCTD (1) . Public Grievance Cell, Department of Power, GNCTD (1) . MNRE, Gol (1) . BEE (1) . MCD (1) . DMRC/Northern Railway (1) . RWAs (2) . Consumer 	<ul style="list-style-type: none"> . HERC (3) . Food and Supplies Department, GoH (1) . Industries Department, GoH (1) . Agriculture Department, GoH (1) . HAREDA (1) . HVPNL (1) . HPGCL (1) . UHBVNL (1) . DHBVNL (1) . RWAs (3) . Northern Railways 	<ul style="list-style-type: none"> . Department of Food & Civil Supplies and Consumer Affairs, GoK (1) . KPTCL (1) . KPCL (1) . BESCO (1) . GESCOM (1) . CPRI (1) . Individual Experts (4) . Industry Groups (3) . RWA (1) . Farmers Organisation (1) . Consumer 	<ul style="list-style-type: none"> . MERC (4) . Food, Civil Supplies and Consumer Protection Department, GoM (1) . Energy and Labour Department, GoM (1) . MNRE, Gol (1) . REC, Western Zone (1) . Central Railway (1) . Industry Groups (4) . Consumer 	<ul style="list-style-type: none"> . RERC (3) . Food, Civil Supplies & Consumer Protection Department, GoR (1) . Department of Agriculture, GoR (1) . Energy Department, GoR (1) . RREC (1) . Labour Commissioner, GoR (1) . RVPNL (1) . RRVUNL (1) . Chairman, Discoms (1)

	Group (1) . Individual Experts (3) . IEX (1) . PTC India (1) . ICAI (1)	(1) . Industry Groups (3) . Panchayats (2) . TERI (1)	Group (1)	Groups (3) . Academic Experts (3) . Indian Energy Exchange (1)	. JVVNL (1) . JDVVNL (1) . AVVNL (1) . North West Railways (1) . Industry Group (1) . Consumer Group (1) . Individual Experts (3)
--	---	--	-----------	--	---

Though the SAC members list for KERC did not include any member of the Commission, the Commission Chairman is the ex-officio Chairman of SAC and Commission members are also ex-officio members. In practice, the consumer advocate also participates in the SAC meetings.

* Other licensees are also invited to the SAC meetings.

4.1.4 Receptivity of SERCs

While all the SERCs have provided space for consumers to voice their concerns during regulatory proceedings, consumers or consumer representatives have often complained that the SERCs did not really listen to what they said. For example, during an interview, a member of a consumer group in Karnataka complained, “KERC listens to our views, but does not act on it.” He went on to add that the Commission has a pre-decided agenda and it follows it. An industry group leader claimed that “consumer participation is just eyewash... regulators are appointed by the government and are subservient to the government... [They] do what the government wants.” The industry groups feel that regulators are favorable to small consumers as the government wants to protect them from rational pricing.

Another example of this lack of trust in the system comes from Haryana where consumers feel that HERC issues orders but they are hardly ever followed by the discoms. Being public utilities, the discoms rarely comply with HERC orders. The state government lacks the will to let regulators be independent and enforce their orders. While the government pretends to be pro-consumer by keeping the tariff artificially low, it seems to be more pro-utility by protecting them from any action from the regulators.

Another impediment to effective consumer participation is that in some cases, the Commission takes a legalistic approach in hearings. For example, in Karnataka, consumers are required to submit their objections/comments on stamp paper. In most cases, there is an increasing presence of professional lawyers representing consumers, even small consumers, in hearings. There are even examples of consumers being represented by lawyers in grievance redressal forums. This is an unwarranted development that may push consumers away from effective participation, increase the cost for participation, and also delay the process.

SERC orders need to provide more explanation for their decisions. Most orders list the comments received from various stakeholders, and also provide the decision taken by the SERC. However, they do not say much about why some views of stakeholders were accepted while others were rejected. Such explanations will not only provide greater social cohesion, but they will also bring about greater accountability on the part of the SERCs.

4.1.5 Efforts to Improve Consumer Participation

Some of the SERCs have taken steps to improve consumer participation. KERC has taken two pioneering initiatives that have put the Commission as a frontrunner in consumer protection and consumer interest representation. First, the Commission has created a fund of Rs 3 crores for consumer education, with a contribution of Rs 1 crore from BESCO and Rs 50 lakhs each from the

other four discoms. This makes Karnataka the only state (among the selected five) to have such a sizable dedicated fund for consumer education. But unfortunately, even three years after its establishment, no money has been spent from this fund.

Second, KERC was the first Commission to set up a dedicated Office of Consumer Advocacy (OCA). The OCA headed by a consultant, with expertise on consumer issues, is responsible to represent the common interests of the consumers, empower consumers to participate effectively in the regulatory process, and arrange the associated consumer education programs, and advise the Commission on matters relating to consumer protection. A consumer expert was appointed to the position and served continuously for 13 years. But his services were terminated in 2013 and the office has been vacant since then. There are mixed opinions about the performance of the OCA. Many people feel that the OCA did reasonably well, with limited capacity and resources, to empower the consumers and raise their awareness. However, the Commission feels that the OCA was not very effective. Rather, members of the commission feel that the officer was pursuing his personal agenda. The officer claims that the Commission was scared of rising consumer awareness, assertion and demands and moreover, the current office bearers of KERC are not pro-consumer.⁸ Generally, the role and significance of OCA cannot be discredited; whether it was sufficiently effective or not, the presence of the office did matter for consumer interest representation, at least symbolically. Currently, the functions of OCA, especially consumer awareness, have been assigned to the Ombudsman and the KERC intends to fill the office soon.

DERC has also taken a few initiatives to raise consumer awareness and better equip the stakeholders to participate in the regulatory proceedings. The Commission has published five public awareness bulletins on some of the technical aspects. However, such initiatives are sporadic and need to be intensified for real outcomes. While the consumer participation in regulatory proceedings appears to be fair in Delhi, there is huge scope for further improvement and meaningful participatory governance in the sector.

4.2 Role of the State Governments and Politicians

While the regulatory process was expected to cater to consumer demands and service levels, it has been observed in various states that political agitation against policy decisions or service levels continues, often at the expense of the regulatory process. The political economy of the power sector ensures that decisions like tariff increases and optimum tariff levels for consumer categories are still part of direct political campaigns in some states, in spite of clear legal provisions mandating that to be the regulator's decision.

State governments have been lukewarm towards institutionalizing consumer participation procedures as per the spirit of Electricity Act. In some cases, as in Maharashtra recently, the state governments have interfered with the regulatory process to stifle consumer participation (see Box 4). In Delhi too, on multiple occasions DERC has revisited its decision (on rational pricing), possibly to accommodate political pressures.

4.3 Limited Space for Deliberations between Stakeholders

Almost all the states view consumer participation as mainly public hearings. This reinforces the view of consumer participation as a one-way communication, almost as in a "*darbar*"⁹ where consumers request the authority, in this case the SERC, to reduce their suffering. Almost no thought is given to consumer participation as active involvement in the decision-making through deliberation. It is expected that during deliberations, participants would move a little closer to transcending their own

⁸ The OCA also claims that the consumer awareness fund was his initiative and he was also instrumental in the shift from three months minimum deposit to two months deposit. However, several others also claim their contribution to the second measure. FKCCI, a leading industry body, seem to have fought a case for the reduction in minimum deposit.

⁹ A ceremonial regal court

private interests and focus instead on the public interest, and exchange arguments and attempt to arrive at solutions that are in the long-term public interest.

This study indicates that there is almost no space for such deliberation between stakeholders. Most of the public participation takes place at public hearings. Technical validation sessions (TVSs), which are held in Maharashtra, are one notable exception. For all tariff-related and other major proceedings, MERC has been inviting the institutional consumer representatives and other select consumer representatives to sessions where the utility, the SERC its staff and consultants are present, to identify any gaps in the filings of the utility. After the utility makes a presentation on its petition, there is a discussion where the various stakeholders can ask questions and identify any gaps in the data. Some of the easier questions, for example about assumptions, are answered during the session. For the others which require more work, the utility provides responses later. Often there can be more than one TVS regarding a petition. However, those sessions focus only on the completeness of the utility's filing and there are no deliberations on the completed filing by the utility, and no questioning about decisions that the SERC may be considering. Unfortunately, even the technical validation sessions may be on their way out in Maharashtra, as discussed in the Box 4.

The concluding section of this paper presents some suggestions for creating more space for deliberations in regulatory proceedings.

4.4 Summary of Assessment of Consumer Participation in the Five States

Although a legal framework for it has been put in place, consumer participation in the electricity regulatory process has not flourished. Effective consumer participation requires more than just the legal framework. It requires a supportive eco-system with four components: (1) space for deliberations between stakeholders; (2) assertive and informed consumer groups; (3) engaging and receptive SERC; and (4) non-interfering government. The five states in this study are at different levels in the achievement of these requirements, but none of them has reached an acceptable level.

5. Analysis and Conclusions

This study of five states in India reveals that while measures for consumer protection and participation have been included in the legislative and regulatory framework for electricity, these measures have not been very effective. The early experience in Maharashtra shows that effective consumer participation did lead to significant improvement in the performance of the electricity sector. However, except for a few rare cases, consumers feel their voice is not heard. Consequently, SERCs lose out on getting the consumers' perspective, which could enhance the information base available to regulators and improve the quality of regulatory decisions. The quality of electricity service continues to be poor, and consumers do not trust the system, making them vulnerable to exploitation by politicians who call for populist measures that actually work against the long term interest of the sector.

5.1 Make Consumers the Focus of Reforms

Reforms of the electricity sector in India were focused primarily on technical issues. While consumer issues were not completely ignored in the legislative and regulatory framework, much less attention was paid to them. Provision of good quality service to consumers and inclusion of consumers' voice in decision-making should be the focus of reforms. UK and Australia have done so through the *Consumer First* program (UK) and *Putting Consumers First* (Australia). These countries have recognized that functioning of the sector is heavily dependent on satisfied and involved consumers. In the US, almost every PUC has a division that is exclusively devoted to consumer affairs. It monitors complaints and compiles statistics through which it informs the respective PUC in its decision-making.

Focusing on consumers requires first understanding their needs. There are multiple options for achieving this understanding. As described earlier, Australia requires that licensees engage with consumers before filing a petition before the regulatory authority. In addition, Australia and the UK

have Consumer Challenge Panels that act as “critical friends” for the regulator and provide the consumers perspective on important issues in regulatory proceedings. Both Australia and UK make special efforts to understand the needs of the vulnerable – the elderly, the sick, and illiterate consumers.

It may be best for the regulatory commissions in India and other such developing countries to have a consumers cell that handles complaints, carries out education programs to increase awareness of CP&P measures, and carries out research to understand consumers’ needs and experience. Because such a cell will be located within the commission, it would be easy for it to provide this information to the Commission, which could, in turn, use it in its decision-making. Further, in order to enhance the receptivity of the Commission to consumer needs, it may be worthwhile to consider a requirement that one member should be either a consumer advocate or a person with extensive experience in consumer issues.

5.2 Effective Consumer Participation Requires a Supportive Eco-System

As this study shows, effective consumer participation requires more than provisions in the regulatory framework for such participation. In order to flourish, it requires a supportive eco-system with four components.

- Space for deliberations in the regulatory process.
- Presence of well-informed and assertive consumer groups or civil society organizations.
- A receptive Commission that proactively engages and interacts with consumers.
- A state government that does not interfere in the regulatory process, thus allowing regulators independence in their functioning.

The following sections elaborate on these requirements.

5.3 Need to Create Space for Deliberations in the Electricity Sector

In order to have effective regulatory decision-making in India, there is a need to move away from the concept of mere participation to deliberation. In other words, consumers and their representatives should not focus solely on presenting consumers’ views but should be actively involved in the decision-making through deliberation. During deliberations, participants are expected to transcend their own private interests and focus instead on the public interest. Participants exchange arguments and attempt to arrive at solutions that are in the long-term public interest. Participation needs to move from the “Information” and “Consultation” stage to the “Influence” and “Partnership” stage (see Section 1.2) where there is some mechanism to ensure that consumers’ inputs are taken into account in the decision-making process, and perhaps even some degree of ‘redistribution’ of decision-making power as consumers are granted the right to negotiate with the regulators and other stakeholders.

Three of the four countries that were studied have provided space for deliberations such that there is give-and-take of views, and the consumer representatives have an opportunity to influence regulatory decisions. UK and Australia use a Consumer Challenge Group and Consumer Challenge Panel respectively wherein a group of consumer experts provides inputs to the regulatory agency in its decisions. In the US, the regulatory framework relies far too much on an adversarial approach to be called truly deliberative. However, the evidentiary hearings where witnesses are cross-examined result in a thorough, if not necessarily collegial, vetting of ideas.

As seen in Section 4.3, in India, there is almost no space for deliberation between stakeholders. Most of the public participation takes place at public hearings. SERCs can create space for deliberations between stakeholders in several ways. The easiest is to have SACs with well-balanced membership that meet regularly to focus on major policy issues. For especially complex issues, the efforts of the SAC could be supplemented by setting-up technical advisory panels. However, the most important and effective way would be to have consultation sessions for each major regulatory

proceeding. All major stakeholders – utilities, SERC staff, select consumer advocates and academics – should be part of these consultative sessions. These consultative sessions could be structured like TVSS in Maharashtra as described in Section 4.3, such all major stakeholders, including consumer representatives and the utility, meet with the SERC and its relevant staff and consultants to discuss important issues in the proceeding that need to be decided.

Some people may argue that the lack of strong consumer advocates in the states may limit the use of such meetings; however, rather than wait until strong consumer advocates are present in a state, it would be best to pursue the creation of regulatory space for deliberations and strengthening consumer advocacy simultaneously.

It would be best to continue having public hearings and consultation sessions where deliberation occurs. The public hearings will provide a check on the process becoming too *expertocratic*. Public hearings provide a corrective mechanism; in addition, many good ideas have been presented there by participants.

5.4 Need for a Strong Advocate for Consumers

Deliberations can be carried out effectively only in small groups. Because the number of small consumers in a utility often runs into millions, there needs to be a representative of these consumers to give voice to their perspective in deliberations. In India, it is particularly important to ensure that the interests of small consumers are represented in regulatory proceedings, since a large majority of small consumers are poor and often uneducated making it more difficult for them to voice their concerns. An illustration of the neglect of the needs of small consumers is that very little research has been done on the quality of electricity service to small consumers. Studies on the quality of service to agricultural consumers are practically non-existent. In fact, even the consumption by these consumers is not known with reports that the consumption is overstated by some utilities to mask high losses. Similarly, while there have been large scale programs to provide access to electricity for previously unconnected areas, there has been almost no research on the quality of the service provided to those consumers.

As the international experience shows, there is a need for a consistently present, technically capable advocate with adequate human and financial resources to represent small consumers. First, such an advocate would represent the interests of small consumers who would otherwise be underrepresented in regulatory proceedings. Second, the advocate would offset the power of the utility which would otherwise have a dominant voice in the regulatory proceedings. Third, the advocate would enhance the information base available to the SERC and thus improve the decision-making by the SERC.

The requirement for technical capability means that the consumer advocate must have a long term involvement in the sector over which such capability can develop. Combined with the need for consistent presence, for effective consumer representation in proceedings, participation by consumer groups cannot be sporadic or according to their whims. Effective consumer representation requires that the consumer representative treats it as its “job.” Simply encouraging CSOs to participate in regulatory proceedings through financial support or training will not be sufficient, because then a CSO will participate only on issues that fits its agenda. This conclusion is supported by the difficulty that has been experienced in various states in getting consumer groups to participate effectively and consistently in electricity regulatory proceedings. Maharashtra is the only exception, but it will be difficult to replicate the Maharashtra experience. Furthermore, designated CRs would be expected to attend the deliberative sessions and will ensure that consumers’ perspective is presented in those sessions.

In countries such as India where most of the distribution companies are state-owned, it would not be appropriate to have the consumer advocate be appointed by the state government as is the case in most of the states in the US. With state-owned utilities, and the SERC already being appointed by

the state government, having a state appointed consumer advocate could very easily lead to a nexus between the utility, the regulator and the consumer advocate.

An alternative is to designate a few CSOs in the state which will be treated as parties to all cases before the SERC and will thus be invited to all proceedings and will be sent copies of all filings in cases before the SERC. This has been done in Maharashtra and has been successful. Another alternative is to have Consumer Challenge Panels (CCPs), as is done in UK and Australia. However, CCPs rely on individual consumer experts, and a sufficient number of them may not be available. Moreover, in India and other such developing countries, the focus should be on building capacity of institutions rather than individuals.

While the designated CR could represent the aggregate interest of all small consumers in the state, there will be a need for representation of vulnerable groups – the poor, farmers, the elderly, etc. It is unfortunate that in India where there are so many poor consumers, there is no group in regulatory proceedings that advocates for poor consumers. Therefore, it is expected that in addition to designated CRs to represent the broad interest of consumers, special interest groups will also participate in regulatory proceedings to represent the interest of vulnerable groups.

The selection of the designated CRs should be independent of the respective state government and SERC. In India, the Forum of Regulators (FoR) is the best suited agency for carrying out the selection. The agency could develop a process for selection of CRs and then select reputed academic or research institutions in each of the major regions of the country to carry out the actual selection of CRs according to the process prescribed by it.

5.5 Setting Up Organizations for CP&P Not Enough - They Must Work Effectively

As this study shows, all the five states have followed the requirements for CP&P as required by the EAct such as: setting up of CGRF, Ombudsman and SAC; and having public hearings for tariff-related proceedings. Yet the quality of CP&P in the states is not up to acceptable levels. Clearly, much more is required to make CP&P effective.

The effect of lack of independence of the CGRF on the quality of grievance redressal highlights the need to pay attention to the details of organizations or agencies being set up for CP&P, particularly on issues of composition of the membership of these organizations, independence of funding, and the process for determination of salary levels.

Furthermore, some of the shortcomings mentioned above may be overcome if the legal or regulatory framework clearly assigns responsibility for ensuring overall effectiveness of the CP&P system. It is recommended that the SERC be made accountable for the effectiveness of the grievance redressal mechanism in the state. This would ensure that it monitors the functioning of the CGRM including the discom's internal complaint handling process, the CGRF and the Ombudsman, in a holistic sense. Such a holistic approach, discussed in the following paragraphs, would ensure that the focus is not just on handling grievances, but also on understanding why grievances are occurring and how to reduce them to a reasonable level.

Rather than working in concert with one another, there is almost no link between the various organizations and processes for CP&P such as the CGRF, the Ombudsman, the SAC; and the SoP. This silo-like approach results in a very ineffective system for consumers. For example, the establishment of CGRFs has provided an opportunity to consumers to present their voice in the form of grievances. But whether they are satisfied or dissatisfied with the outcomes, and whether the overall CGR process is effective, there is almost no further attention paid to these issues in the regulatory process. It seems that the consumers' voice is heard only in the limited confines of the CGRF and Ombudsman office, and it is not amplified, or even carried forward, in the regulatory process by the Commission to affect regulatory decisions.

In order to be really effective, the entire CGR mechanism needs to be seen as a system, as shown in Figure 8. While addressing grievances is important, the purpose of having a CGR mechanism should not be simply to handle grievances, instead it should also be used to understand why grievances are occurring and to reduce them to a reasonable level. That goal requires that the CGR mechanism be used by the SERC to monitor all stages of the CGR process, evaluate the performance of each stage, and carry forward the information into the regulatory decision making process. As shown in Figure 8, for this purpose, the CGR mechanism should include the following tasks:

- Periodically obtain from the discoms data about all complaints lodged by consumers over that period. Compare the aggregate data on complaints with the benchmarks for aggregate performance measures in the SoP, such as the total number and duration of outages. Ensure that the resulting information about discom performance flows into the regulatory decision making for tariffs etc. for the respective discom. Also compare the performance of the internal complaint handling system of the discom with the benchmarks for individual complaints in the SoP and carry forward that information too into the regulatory decision-making process. Because the SERC will have the required data, it should order the discom to provide compensation, through bill reduction, to those consumers who are eligible for it.
- Similarly, periodically obtain information from the CGRF about the grievances handled over that period. Some CGRFs already provide such information to the SERC either directly or through the Ombudsman. The SERC should monitor the performance of the CGRF in terms of the time taken to resolve grievances. It should see if there are any patterns to the cases handled by the CGRF. What proportion of cases is decided in favor of consumers? Is there any class of consumer that very rarely files a petition at the CGRF? This is may be due to lack of capacity, resources or awareness. Do the utilities in the state comply with CGRF orders? If not, why not? The SERC should push the utilities to comply.
- The SERC should monitor the performance of the Ombudsman in a similar fashion.
- All the information about the performance of the discom and the CGR mechanism should flow into regulatory decision-making. This way the voice of the consumers can be carried forward and amplified by the regulator.

Some states are following at least some steps in this approach to improving the quality of service. For example, Gujarat Electricity Regulatory Commission (GERC) holds regular review meetings to review the performance and facilitate learning across CGRFs. Until recently, DERC was also having regular meetings with the CGRFs, the Ombudsman and the discoms to discuss various aspects of the CGRM and impediments to improving performance.

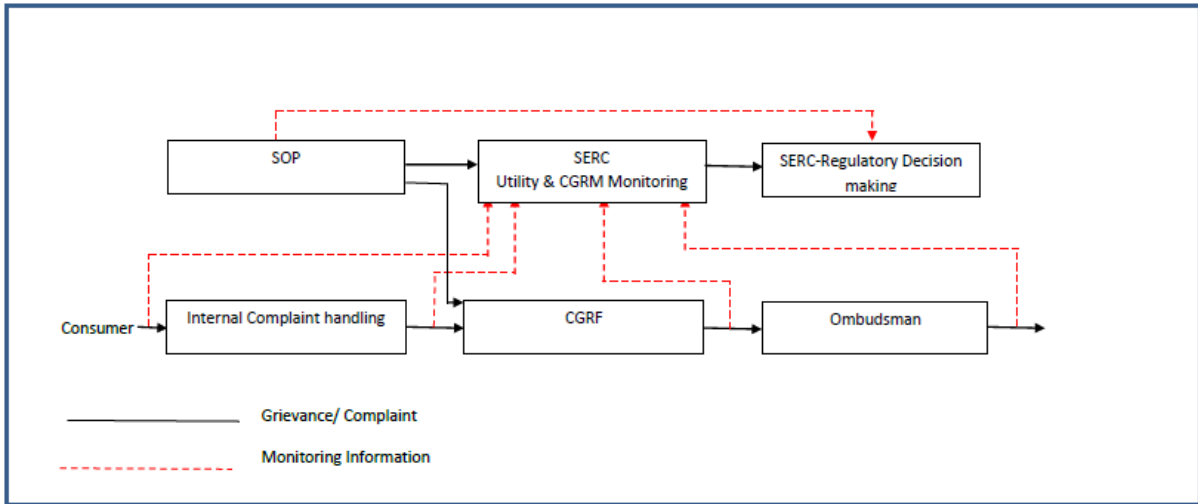

Figure 8: Holistic Approach to Consumer Protection and Participation

5.6 Need for Ongoing Evaluation of Systems for Consumer Protection and Participation

No regulatory regime works perfectly from the first day. As the UK and Australian experience shows, there is a need to make modifications as and when necessary. Therefore, mechanisms need to be built into the regulatory structure for consumer protection and participation for ongoing monitoring of how well it is working, and for making modifications when required. Unfortunately, in India not much attention has been paid to monitoring and evaluation.

Implementing the small, incremental changes listed here can significantly improve the quality of electricity services for Indian citizens through improvements in grievance redressal and more effective consumer participation. These changes will also build greater trust in the system among consumers, leading to greater ground-up support for regulatory decisions and the reform process. Furthermore, inputs from consumers will enhance the information base available to regulators, thus enhancing the quality of regulatory decisions. These suggestions should be useful not only for Indian states, but also for other developing countries as they reform their power sectors.

References:

- AER. 2014. *Overview of the Better Regulation reform package*. Australian Energy Regulator,
- ANEEL. 2014. Agencia Nacional de Energia Electrica (Brazilian Electricity Regulatory Agency) website; www.aneel.gov.br
- Arnstein, S. R. 1969. A Ladder of Citizen Participation. *Journal of the American Institute of Planners*, 35, 216-224.
- ATE. 2014. Appeal of Tata Motors Limited versus Maharashtra Electricity Regulatory Commission and Maharashtra State Electricity Distribution Company Limited, Appellate Tribunal for Electricity, Appeal No. 295 of 2013, 22 August 2014.
- ATE. 2014. Appeal of Tata Motors Limited versus Maharashtra Electricity Regulatory Commission and Maharashtra State Electricity Distribution Company Limited, Appellate Tribunal for Electricity, Appeal No. 295 of 2013, 22 August 2014.
- Australian Government. 2014. *Green Paper 2014 to inform preparation of a White Paper*. Australian Government, Department of Industry.
- CA-ORA. 2014. 2013 Annual Report. Office of Ratepayer Advocates, San Francisco, California; January 10.
- Castro, C. M. d. 2013. Public hearings as a tool to improve participation in regulatory policies: case study of the National Agency of Electric Energy. *Rev. Adm. Publica*. 47(5), 1069-87.
- Citizens Advice. 2014. *The experience of small businesses as consumers in regulated markets – A report for Citizens Advice*. BMG Research, Citizens Advice, London.
- Crew, M. A. & Parker, D. 2006. *International Handbook on Economic Regulation*. Cheltenham: Edward Elgar Publishing.
- CT-OCC. 2011. OCC Newsletter, Summer 2011; Connecticut Office of Consumer Counsel.
- CT-OCC. 2012a. Annual Report for FY 2012, Connecticut Office of Consumer Counsel.
- CT-OCC. 2012b. Scorecard Savings for July 1, 2011 – June 30, 2012. Connecticut Office of Consumer Counsel.
- CUAC. 2013. *Meaningful & Genuine Engagement – Perspectives from consumer advocates*. A CUAC Research Report, Consumer Utilities Advocacy Centre, Melbourne, Victoria, Australia.
- CUTS, 2015. Transforming Electricity Governance in India – Consumer Participation and Protection in Regulatory Practice. Consumer Unity & Trust Society, http://www.cuts-ccier.org/CPSER/pdf/CUTS_Research_Report-Transforming_Electricity_Governance_in_India.pdf. February 2015.
- ECA. 2015. Website of Energy Consumers Australia Ltd, www.energyconsumersaustralia.com.au accessed on 16th March 2015.
- Fremeth, A.R., Holburn, G.L.F., and Siller, P.T., 2013. The impact of consumer advocates on regulatory policy in the electric utility sector. *Public Choice*, Vol. 157 Nos. 3-4, December 2013.

- Gormley, W. T. J. 1983. Policy, Politics, and Public Utility Regulation. *American Journal of Political Science*, 27 (1), 86-105.
- Graham, C. 2014. Email communication with Cosmos Graham, Professor, School of Law, and Director, Centre for Consumers and Essential Services (CCES), University of Leicester, UK; October 2014.
- Houston, G. 2014. Consumer Advocacy in Australian Regulatory Decision Making - 'Hard Choices Await'. *Network Industries Quarterly*, 16 (1).
- IL-CUB. 2012. The CUB VOICE. Citizens Utility Board, Chicago, Illinois, Winter.
- MDRA. 2013. Survey of Electricity Consumers to Assess the Level of Consumer Awareness on Consumer Rights & Consumer Grievance Redressal Mechanism Within the areas of - Maharashtra State Electricity Distribution Company Ltd., Mumbai: Maharashtra Electricity Regulatory Commission.
- MERC. 2010. Minutes of the 13th SAC Meeting. Maharashtra Electricity Regulatory Commission, 26 March.
- MERC. 2010. Presentation at Workshop on Redressal of Consumers' Grievances, Maharashtra Electricity Regulatory Commission, January 29.
- MERC. 2014. CGRF Report April 12- March 13. Analysis of grievances handled by the CGRFs during the period April 12- March 13, Maharashtra Electricity Regulatory Commission, www.mercindia.org.in, accessed 8 April 2014.
- Mitcham, C. 1997. Justifying Public Participation in Technical Decision Making. *IEEE Technology and Society Magazine*, Spring, 40-46.
- Muzzini, E. 2005. Consumer Participation in Infrastructure Regulation: Evidence from the East Asia and Pacific Region. *World Bank Working Paper No. 66*. Washington DC: The World Bank.
- MVGS. 2014. Letter to the Chief Secretary, State Government of Maharashtra, Mumbai regarding request to remove Smt. Chandra Iyengar as member and chairperson of Maharashtra Electricity Regulatory Commission, Mumbai under Section 90 of EA 2003 "for misuse and abuse of powers prejudicial to the Public Interest;" Maharashtra Veej Grahak Sanghatana, Ichalkaranji, Distt. Kolhapur, Maharashtra, 27 October 2014.
- NH-OCA. 2012. Biennial Report, 2012. Office of the Consumer Advocate, New Hampshire.
- OECD. 2008. *OECD Reviews of Regulatory Reform: Brazil – Strengthening Governance for Growth*. OECD.
- Ofgem, 2011. Guidance on Ofgem's approach to consultations. Office of Gas and Electricity Markets, 20 December 2011. www.ofgem.gov.uk accessed on 20 April 2015.
- Pargal, S. & Bannerjee, S. G. 2014. *More Power to India: The Challenge of Electricity Distribution*. Washington DC: The World Bank.
- Puri, E. 2004. Understanding Participation: Theoretical Foundations and Practical Implications. *Economic and Political Weekly*, 39, 2511-2517.
- RAP. 2014. Regulatory Assistance Project. The Creation of a Consumer Advocate for Puerto Rico, March.

- Reeves, A. 2013. Evolving Australia's Energy Network Regulation: Consumers in Focus, *The ICER Chronicle*, International Confederation of Energy Regulators, http://www.icer-regulators.net/portal/page/portal/ICER_HOME/publications_press/ICER_Chronicle/Art_11, accessed October 26, 2014.
- Rossi, J. 1997. Participation Run Amok: The Costs of Mass Participation for Deliberative Agency Decisionmaking. *Northwestern University Law Review*, 92, 173.
- Sevel, F. 2001. The Evolution of the Consumer Affairs Department in the State of Regulation: An Examination of the Four Utility Sectors, NRRI, July.
- Stein, D. G. 2012. Perilous Proxies: Issues of Scale for Consumer Representation in Agency Proceedings. *NYU Annual Survey of American Law*, 67, 513.
- Thomas, S. 2014. Presentation on Case example on energy markets: The UK Power Market; Business School, University of Greenwich.
- Tol. 2011. Ajit Pawar in tangles over power commission's head. *Times of India*, Mumbai, April 25.
- World Bank. 2003. *World Development Report 2004: Making Services Work for Poor People*. New York: The World Bank & Oxford University Press.